

CITY OF OCEAN CITY
CAPE MAY COUNTY, NEW JERSEY

RESOLUTION

#1

REMEMBERING RICHARD P. GALANTE

WHEREAS, Richard P. Galante, 86, passed away on Sept. 2, 2017 with his family by his side; and

WHEREAS, Galante’s life was dedicated to the service of his family, friends, country and community; and

WHEREAS, Galante proudly served in the U.S. Navy for four years that included the Korean War; and

WHEREAS, Galante and fellow veterans returning from World War II and the Korean War helped build the Veterans of Foreign Wars post in Ocean City, and he remained an active member and officer for the rest of his life; and

WHEREAS, world-renowned author and Ocean City native Gay Talese once called him the “best second baseman ever” ... not just the best in Ocean City but the “best ever”; and

WHEREAS, Galante earned nine varsity letters in football, basketball and baseball and was named Mr. Ocean City High School for exemplifying school spirit; and

WHEREAS, Galante emphatically answered the question, “Are you smarter than a fifth-grader?” when he moved to Ocean City in fifth grade and tested into a sixth-grade placement; and

WHEREAS, Galante owned and operated a bricklayers company in Ocean City for more than 30 years and founded a local bike and surrey rental business; and

WHEREAS, People like Dick – regular salt-of-the-earth guys – are what make our town great.

NOW, THEREFORE, BE IT RESOLVED, by the City Council of Ocean City, NJ, on behalf of all citizens, that Richard Galante is honored and sincerely thanked for his outstanding service to the City of Ocean City, NJ; and

BE IT FURTHER RESOLVED, that Galante’s wife, Edie; children Tony and Lori; and all of his extended family and friends are extended our deepest condolences.

Peter V. Madden
Council President

Anthony P. Wilson

Michael DeVlieger

Robert S. Barr

Keith P. Hartzell

Karen Bergman

Antwan L. McClellan

Offered by Seconded by

The above resolution was duly adopted by the City Council of the City of Ocean City, New Jersey, at a meeting of said Council duly held on the day of 2017.

NAME	AYE	NAY	ABSENT	ABSTAINED
Barr	_____	_____	_____	_____
Bergman	_____	_____	_____	_____
DeVlieger	_____	_____	_____	_____
Hartzell	_____	_____	_____	_____
Madden	_____	_____	_____	_____
McClellan	_____	_____	_____	_____
Wilson	_____	_____	_____	_____

.....
City Clerk

ORDINANCE NO. 17-18

**BOND ORDINANCE PROVIDING FOR ACQUISITION OF
PROPERTY IN AND BY THE CITY OF OCEAN CITY, IN
THE COUNTY OF CAPE MAY, NEW JERSEY,
APPROPRIATING \$700,000 THEREFOR AND
AUTHORIZING THE ISSUANCE OF \$665,000 BONDS OR
NOTES OF THE CITY TO FINANCE PART OF THE COST
THEREOF**

BE IT ORDAINED BY THE CITY COUNCIL OF THE CITY OF OCEAN CITY, IN THE COUNTY OF CAPE MAY, NEW JERSEY (not less than two-thirds of all members thereof affirmatively concurring) AS FOLLOWS:

Section 1. The improvement described in Section 3(a) of this bond ordinance is hereby authorized to be undertaken by the City of Ocean City, in the County of Cape May, New Jersey (the "City") as a general improvement. For the improvement or purpose described in Section 3(a), there is hereby appropriated the sum of \$700,000, including the sum of \$35,000 as the down payment required by the Local Bond Law. The down payment is now available by virtue of provision for down payment or for capital improvement purposes in one or more previously adopted budgets.

Section 2. In order to finance the cost of the improvement or purpose not covered by application of the down payment, negotiable bonds are hereby authorized to be issued in the principal amount of \$665,000 pursuant to the Local Bond Law. In anticipation of the issuance of the bonds, negotiable bond anticipation notes are hereby authorized to be issued pursuant to and within the limitations prescribed by the Local Bond Law.

Section 3. (a) The improvement hereby authorized and the purpose for the financing of which the bonds are to be issued is the acquisition of property known as 50 Tennessee Avenue, listed as Block 3350, Lot 15.01 on the municipal tax map, including all related costs and expenditures necessary therefor and incidental thereto.

(b) The estimated maximum amount of bonds or bond anticipation notes to be issued for the improvement or purpose is as stated in Section 2 hereof.

(c) The estimated cost of the improvement or purpose is equal to the amount of the appropriation herein made therefor.

Section 4. All bond anticipation notes issued hereunder shall mature at such times as may be determined by the chief financial officer; provided that no bond anticipation note shall mature later than one year from its date. The bond anticipation notes shall bear interest at such

rate or rates and be in such form as may be determined by the chief financial officer. The chief financial officer shall determine all matters in connection with bond anticipation notes issued pursuant to this bond ordinance, and the chief financial officer's signature upon the bond anticipation notes shall be conclusive evidence as to all such determinations. All bond anticipation notes issued hereunder may be renewed from time to time subject to the provisions of the Local Bond Law. The chief financial officer is hereby authorized to sell part or all of the bond anticipation notes from time to time at public or private sale and to deliver them to the purchasers thereof upon receipt of payment of the purchase price plus accrued interest from their dates to the date of delivery thereof. The chief financial officer is directed to report in writing to the governing body at the meeting next succeeding the date when any sale or delivery of the bond anticipation notes pursuant to this bond ordinance is made. Such report must include the amount, the description, the interest rate and the maturity schedule of the bond anticipation notes sold, the price obtained and the name of the purchaser.

Section 5. The City hereby certifies that it has adopted a capital budget or a temporary capital budget, as applicable. The capital or temporary capital budget of the City is hereby amended to conform with the provisions of this bond ordinance to the extent of any inconsistency herewith. To the extent that the purposes authorized herein are inconsistent with the adopted capital or temporary capital budget, a revised capital or temporary capital budget has been filed with the Division of Local Government Services.

Section 6. The following additional matters are hereby determined, declared, recited and stated:

(a) The improvement or purpose described in Section 3(a) of this bond ordinance is not a current expense. It is an improvement or purpose that the City may lawfully undertake as a general improvement, and no part of the cost thereof has been or shall be specially assessed on property specially benefitted thereby.

(b) The period of usefulness of the improvement or purpose within the limitations of the Local Bond Law, according to the reasonable life thereof computed from the date of the bonds authorized by this bond ordinance, is 40 years.

(c) The Supplemental Debt Statement required by the Local Bond Law has been duly prepared and filed in the office of the Clerk, and a complete executed duplicate thereof has been filed in the office of the Director of the Division of Local Government Services in the

Department of Community Affairs of the State of New Jersey. Such statement shows that the gross debt of the City as defined in the Local Bond Law is increased by the authorization of the bonds and notes provided in this bond ordinance by \$665,000, and the obligations authorized herein will be within all debt limitations prescribed by the Local Bond Law.

(d) An aggregate amount not exceeding \$50,000 for items of expense listed in and permitted under N.J.S.A. 40A:2-20 is included in the estimated cost indicated herein for the purpose or improvement.

Section 7. The City hereby declares the intent of the City to issue bonds or bond anticipation notes in the amount authorized in Section 2 of this bond ordinance and to use the proceeds to pay or reimburse expenditures for the costs of the purposes described in Section 3(a) of this bond ordinance. This Section 7 is a declaration of intent within the meaning and for purposes of Treasury Regulations.

Section 8. Any grant moneys received for the purpose described in Section 3 hereof shall be applied either to direct payment of the cost of the improvement or to payment of the obligations issued pursuant to this bond ordinance. The amount of obligations authorized but not issued hereunder shall be reduced to the extent that such funds are so used.

Section 9. The chief financial officer of the City is hereby authorized to prepare and to update from time to time as necessary a financial disclosure document to be distributed in connection with the sale of obligations of the City and to execute such disclosure document on behalf of the City. The chief financial officer is further authorized to enter into the appropriate undertaking to provide secondary market disclosure on behalf of the City pursuant to Rule 15c2-12 of the Securities and Exchange Commission (the "Rule") for the benefit of holders and beneficial owners of obligations of the City and to amend such undertaking from time to time in connection with any change in law, or interpretation thereof, provided such undertaking is and continues to be, in the opinion of a nationally recognized bond counsel, consistent with the requirements of the Rule. In the event that the City fails to comply with its undertaking, the City shall not be liable for any monetary damages, and the remedy shall be limited to specific performance of the undertaking.

Section 10. The full faith and credit of the City are hereby pledged to the punctual payment of the principal of and the interest on the obligations authorized by this bond ordinance. The obligations shall be direct, unlimited obligations of the City, and the City shall be obligated

to levy *ad valorem* taxes upon all the taxable real property within the City for the payment of the obligations and the interest thereon without limitation of rate or amount.

Section 11. The Mayor, City Administrator, City Clerk and City Attorney, as the case may be, are authorized pursuant to N.J.S.A. 40A:12-1 *et seq.*, and any other applicable law, to prepare and sign any and all necessary documentation to effectuate the acquisition as described herein, concerning the property known as 50 Tennessee Avenue, listed as Block 3350, Lot 15.01 on the municipal tax map, including, but not limited to, any contracts and amendments thereto and all closing documents needed to complete the purchase.

Section 12. This bond ordinance shall take effect 20 days after the first publication thereof after final adoption, as provided by the Local Bond Law.

ORDINANCE #17-17

AN ORDINANCE AMENDING ORDINANCE #87-17, CHAPTER XXX "MUNICIPAL FEES" OF THE REVISED GENERAL ORDINANCES OF THE CITY OF OCEAN CITY, NEW JERSEY (Fee for Permit to Dredge Private Areas)

THE GOVERNING BODY OF THE CITY OF OCEAN CITY, NEW JERSEY DOES HEREBY ORDAIN AS FOLLOWS:

SECTION 1.

CHAPTER XXX "Municipal Fees" of the revised General Ordinances of the City of Ocean City, New Jersey is hereby amended to include the following in Schedule B:

	<u>Permit Fee</u>	<u>Inspection Escrow</u>
Contractor's Application for Municipal Permit To Dredge Privately-Owned Areas Under the Authority of Ocean City's Individual Permit	\$200.00	\$ 3.00/cy to be removed

SECTION 2.

If any portion of this ordinance is declared invalid by a Court of competent jurisdiction, it shall not affect the remaining portions of the Ordinance which shall remain in full force and effect.

SECTION 3.

All ordinances or portions thereof inconsistent with this Ordinance are repealed to the extent of such inconsistency.

SECTION 4.

This Ordinance shall take effect in the time and manner prescribed by law.

CITY OF OCEAN CITY
CAPE MAY COUNTY, NEW JERSEY

RESOLUTION

#2

AUTHORIZING THE AWARD OF CITY CONTRACT #17-50, FURNISHING & INSTALLATION OF INDOOR CYCLING BIKES AT THE AQUATIC & FITNESS CENTER

WHEREAS, specifications were authorized for advertisement by Resolution #17-53-245 on Thursday, August 22, 2017 for City Contract #17-50, Furnishing & Installation of Indoor Cycling Bikes at the Aquatic & Fitness Center; and

WHEREAS, the Notice to Bidders was advertised in the Ocean City Sentinel on Wednesday, August 30, 2017, the Notice to Bidders was posted on the City of Ocean City's website @ www.ocnj.us and Invitation for Bid proposals was distributed to three (3) prospective bidder(s) for City Contract #17-50, Furnishing & Installation of Indoor Cycling Bikes at the Aquatic & Fitness Center; and

WHEREAS, bid proposals were opened for City Contract #17-50, Furnishing & Installation of Indoor Cycling Bikes at the Aquatic & Fitness Center on Tuesday, September 19, 2017 and one (1) bid proposal was received; and

WHEREAS, Michael J. Allegretto, Director of Community Services; Wendy Moyle, Manager of Recreation Programs; Darleen H. Korup, Purchasing Assistant-Typing; Allison L. Hansen, Assistant Purchasing Agent and Joseph S. Clark, QPA, City Purchasing Manager have reviewed the bid proposal and specifications and recommend that City Contract #17-50, Furnishing & Installation of Indoor Cycling Bikes at the Aquatic & Fitness Center be awarded to Core Health & Fitness, LLC the lowest responsible bidder; and

NOW THEREFORE, BE IT RESOLVED by the City Council of the City of Ocean City, New Jersey that City Contract #17-50, Furnishing & Installation of Indoor Cycling Bikes at the Aquatic & Fitness Center be and is hereby awarded to the following lowest responsible bidder as follows:

Core Health & Fitness, LLC
4400NE 77th Avenue, Suite 300
Vancouver, WA 98662

<u>Item</u>	<u>Description</u>	<u>Est. Quantity</u>	<u>Unit Price</u>	<u>Total Price</u>
1.	A.C. Performance Plus™ with Carbon Blue™	25 Each	\$ 1,266.32	\$ 31,658.00
2.	MPower™ Echelon2 with Power Package	25 Each	\$ 260.50	\$ 6,512.50
TOTAL BID PRICE:				\$ 38,170.50

BE IT FURTHER RESOLVED that the Mayor and the City Purchasing Manager are hereby authorized to enter into a contract with Core Health & Fitness, LLC, 4400NE 77th Avenue, Suite 300, Vancouver, WA 98662 for City Contract #17-50, Furnishing & Installation of Indoor Cycling Bikes at the Aquatic & Fitness Center as listed and in accordance with the bid specifications and the bid proposal form.

The Director of Financial Management certifies that funds are available and shall be charged to the following Capital Account #'s: C-04-55-294-508 - \$31,658.13 (BARR) & C-04-55-301-610 - \$6,512.37 (MADDEN)

CERTIFICATION OF FUNDS



Frank Donato III, CMFO
Director of Financial Management

Peter V. Madden
Council President

Files: RAW 17-50, Cycle Bikes.doc

Offered by Seconded by

The above resolution was duly adopted by the City Council of the City of Ocean City, New Jersey, at a meeting of said Council duly held on the day of 2017

NAME	AYE	NAY	ABSENT	ABSTAINED
Barr	_____	_____	_____	_____
Bergman	_____	_____	_____	_____
DeVlieger	_____	_____	_____	_____
Hartzell	_____	_____	_____	_____
Madden	_____	_____	_____	_____
McClellan	_____	_____	_____	_____
Wilson	_____	_____	_____	_____

.....
Melissa G. Bovera, City Clerk

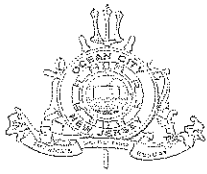

CITY OF OCEAN CITY

AMERICA'S GREATEST FAMILY RESORT

PURCHASING DIVISION
SUMMARY OF BID PROPOSALS

BY THE GOVERNING BODY OF THE CITY OF OCEAN CITY, NJ

DATE RECEIVED: Tuesday, September 19, 2017 @ 2:00 PM, EDT
CITY CONTRACT #: 17-50
PROPOSAL NAME: Furnishing & Installation of Indoor Cycling Bikes
 at the Aquatic & Fitness Center

NAME, ADDRESS & BID OF EACH BIDDER		Core Health & Fitness LLC 4400 NE 77th Ave, Suite 300 Vancouver, WA 98662 Chris Ruggiero, Territory Manager P: 347-440-4871 cruggiero@corehandf.com								
ITEM	DESCRIPTION	Qty.	Unit Price	Total Price	Unit Price	Total Price	Unit Price	Total Price	Unit Price	Total Price
1.	A.C. Performance Plus™ with Carbon Blue™	25	\$1,266.32	\$31,658.00						
2.	MPower™ Echelon2 with Power Package	25	\$260.50	\$6,512.50						
TOTAL BID PRICE:				\$38,170.50						
DOCUMENTATION										
	Required Number of Copies (2):	Y/N	Yes	Y/N		Y/N		Y/N		
	Buy American Certification:	Y/N	Yes	Y/N		Y/N		Y/N		
	Right to Extend - Time for Award:	Y/N	Yes	Y/N		Y/N		Y/N		
	Statement of Ownership Disclosure:	Y/N	Yes	Y/N		Y/N		Y/N		
	Non-Collusion Affidavit:	Y/N	Yes	Y/N		Y/N		Y/N		
	Mandatory Equal Employment Opportunity Language:	Y/N	Yes	Y/N		Y/N		Y/N		
	NJ Affirmative Action Regulation Compliance Notice:	Y/N	Yes	Y/N		Y/N		Y/N		
	Required Subcontractors Listing:	Y/N	None Required	Y/N	None Required	Y/N	None Required	Y/N	None Required	None Required
	Acknowledge of Receipt of Addenda:	Y/N	None Issued	Y/N	None Issued	Y/N	None Issued	Y/N	None Issued	None Issued
	Disclosure of Investment Activities in Iran Statement-Two Part Form:	Y/N	Yes	Y/N		Y/N		Y/N		
	NJ Business Registration Certificate (BRC):	Y/N	Yes	Y/N		Y/N		Y/N		
	Statement of Authority:	Y/N	Yes	Y/N		Y/N		Y/N		
	W-9:	Y/N	Yes	Y/N		Y/N		Y/N		

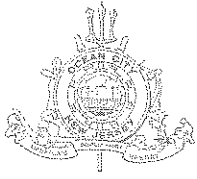

CITY OF OCEAN CITY

AMERICA'S GREATEST FAMILY RESORT

DEPARTMENT OF COMMUNITY SERVICES
Division of Aquatic & Fitness Center

Date: September 20, 2017

Memo To: Joseph S. Clark, QPA, Purchasing Manager

From: Wendy Moyle, Recreation Manager

Re: Award City Contract 17-50

I have reviewed the bid of Core Health and Fitness for City contract 17-50, 25 Indoor Cycling Schwinn AC Performance Plus bikes with 25 Schwinn MPower Echelon 2 Consoles. I approve Core Health and Fitness as the successful bidder for this capital purchase for the Aquatic and Fitness Center.

Thanks very much!

CITY OF OCEAN CITY
CAPE MAY COUNTY, NEW JERSEY

RESOLUTION

#3

**AUTHORIZING THE AWARD OF CITY CONTRACT #18-15,
18-15, 2018 IMPROVEMENTS TO VARIOUS PLAYGROUND FACILITIES**

WHEREAS, specifications were authorized for advertisement by Resolution #17-53-249 on Thursday, August 22, 2017 for City Contract #18-15, 2018 Improvements to Various Playground Facilities; and

WHEREAS, the Notice to Bidders was advertised in the Sentinel Ledger on Wednesday, August 30, 2017, the Notice to Bidders was posted on the City of Ocean City's website @ www.ocnj.us and the Invitation for Bid Proposals was distributed to twenty-four (24) prospective bidder(s) for City Contract #18-15, 2018 Improvements to Various Playground Facilities; and

WHEREAS, bid proposals were opened for City Contract #18-15, 2018 Improvements to Various Playground Facilities on Tuesday, September 19, 2017 and three (3) bid proposals were received per the attached Summary of Bid Proposals; and

WHEREAS, Arthur J. Chew, PE, PP, CFM, CME, CPWM, Assistant City Engineer; Steven M. Longo, Manager of Public Buildings & Grounds; Jason J. Sieira, Manager of Capital Planning; Darleen H. Korup, Purchasing Assistant; Allison L. Hansen, Assistant Purchasing Agent and Joseph S. Clark, QPA, City Purchasing Manager have reviewed the bid proposals and specifications and recommended that the contract be awarded to Whirl Corporation, Inc. the lowest responsible bidder; and

NOW THEREFORE, BE IT RESOLVED by the City Council of the City of Ocean City, New Jersey, that City Contract #18-15, 2018 Improvements to Various Playground Facilities be and is hereby awarded to the following lowest responsible bidder as follows:

**Whirl Corporation, Inc.
P.O. Box 110
194 Main Street
Port Monmouth, NJ 07758**

<u>Item</u>	<u>Description</u>	<u>Quantity</u>	<u>Unit Price</u>	<u>Total Price</u>
<u>Base Bid</u>				
8th Street Playground Improvements				
1	Soil Erosion & Sediment Control	1 Lump Sum	\$ 3,500.00	\$ 3,500.00
2	Playground Equipment - Install	1 Lump Sum	\$ 35,000.00	\$ 35,000.00
3	Unitary Flexible Porous Mulch	7,000 S.F.	\$ 16.50	\$ 115,500.00
4	4 Coat Color System Basketball Surface	900 S.Y.	\$ 24.44	\$ 21,996.00
5	Basketball Standard - Install	2 Unit	\$ 3,000.00	\$ 6,000.00
Total Amount - Base Bid, Items 1 - 5:				\$ 181,996.00
<u>Alternate A</u>				
North Street Playground Improvements				
6	Soil Erosion & Sediment Control	1 Lump Sum	\$ 2,500.00	\$ 2,500.00
7	Playground Equipment - Install	1 Lump Sum	\$ 25,300.00	\$ 25,300.00
8	Unitary Flexible Porous Mulch	2,250 S.F.	\$ 16.42	\$ 36,945.00
9	Concrete Sidewalk, 4" Thick	30 S.Y.	\$ 135.00	\$ 4,050.00
10	8"x18" Concrete Vertical Curb	60 L.F.	\$ 80.00	\$ 4,800.00
Total Amount - Alternate A, Items 6 - 10:				\$ 73,595.00
Total Amount for Both Base and Alternate A				\$ 255,591.00

CITY OF OCEAN CITY
CAPE MAY COUNTY, NEW JERSEY

RESOLUTION

BE IT FURTHER RESOLVED that the Mayor and the City Purchasing Manager are hereby authorized to enter into a contract with Whirl Corporation, Inc., P.O. Box 110, 194 Main Street, Port Monmouth, NJ 07758 for City Contract #18-15, 2018 Improvements to Various Playground Facilities as listed and in accordance with the bid specifications and the bid proposal form.

The Director of Financial Management certifies that funds are available and shall be charged to the following Capital Account #'s: C-04-55-301-408 - \$181,996.00 & C-04-55-301-409 - \$73,595.00.

CERTIFICATION OF FUNDS



Frank Donato III, CMFO
Director of Financial Management

Peter V. Madden
Council President

Files: RAW 18-15Imporvemnts to Various Playground.doc

Offered by Seconded by

The above resolution was duly adopted by the City Council of the City of Ocean City, New Jersey, at a meeting of said Council duly held on the day of 2017

NAME	AYE	NAY	ABSENT	ABSTAINED
Barr	_____	_____	_____	_____
Bergman	_____	_____	_____	_____
DeVlieger	_____	_____	_____	_____
Hartzell	_____	_____	_____	_____
Madden	_____	_____	_____	_____
McClellan	_____	_____	_____	_____
Wilson	_____	_____	_____	_____

.....
Melissa G. Bovera, City Clerk

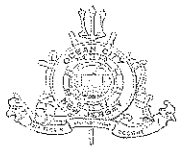

CITY OF OCEAN CITY

AMERICA'S GREATEST FAMILY RESORT

PURCHASING DIVISION
SUMMARY OF BID PROPOSALS

DATE RECEIVED: Tuesday, September 19, 2017 @ 2:00 PM, EDT
CITY CONTRACT #: 18-15
PROPOSAL NAME: 2018 Improvements to Various Playground Facilities

BY THE GOVERNING BODY OF THE CITY OF OCEAN CITY, NJ

NAME, ADDRESS & BID OF EACH BIDDER				Command Co., Inc.		Picerno-Giordano Construction, LLC		Whirl Corporation, Inc.			
Key: Apparent Low Bidder Engineer's Estimate for Base Bid & Alternate A: \$262,150.00				1318 Antwerp Avenue		200 Market Street		P.O. Box 110, 194 Main Street			
				Egg Harbor City, NJ 08215-2865		Kenilworth, NJ 07033		Port Monmouth, NJ 07758			
				Douglas E. Marienski, President		Toni Giordano Picerno, Managing Member		James B. Davis, Vice President			
				P: 609-965-0399		P: 908-241-4331		P: 732-495-3715			
				F: 609-965-0441		F: 908-241-7854		F: 732-495-6133			
				dougm@commandcoinc.com		nina@picernogiordano.com		info@whirlconstruction.net			
ITEM	DESCRIPTION	QTY	UNIT	UNIT COST	TOTAL COST	UNIT COST	TOTAL COST	UNIT COST	TOTAL COST	UNIT COST	TOTAL COST
BASE BID											
8th Street Playground Improvements											
1	SOIL EROSION AND SEDIMENT CONTROL	1	LUMP SUM	\$100.00	\$100.00	\$2,500.00	\$2,500.00	\$3,500.00	\$3,500.00		
2	PLAYGROUND EQUIPMENT - INSTALL	1	LUMP SUM	\$65,000.00	\$65,000.00	\$97,960.00	\$97,960.00	\$35,000.00	\$35,000.00		
3	UNITARY FLEXIBLE POROUS MULCH	7,000	S.F.	\$17.00	\$119,000.00	\$15.50	\$108,500.00	\$16.50	\$115,500.00		
4	4 COAT COLOR SYSTEM BASKETBALL SURFACE	900	S.Y.	\$10.00	\$9,000.00	\$20.25	\$18,225.00	\$24.44	\$21,996.00		
5	BASKETBALL STANDARD - INSTALL	2	UNIT	\$2,400.00	\$4,800.00	\$3,000.00	\$6,000.00	\$3,000.00	\$6,000.00		
TOTAL AMOUNT - BASE BID, ITEMS 1 - 5:					\$197,900.00		\$233,185.00		\$181,996.00		
ALTERNATE A											
North Street Playground Improvements											
6	SOIL EROSION AND SEDIMENT CONTROL	1	LUMP SUM	\$100.00	\$100.00	\$2,500.00	\$2,500.00	\$2,500.00	\$2,500.00		
7	PLAYGROUND EQUIPMENT - INSTALL	1	LUMP SUM	\$45,600.00	\$45,600.00	\$70,578.00	\$70,578.00	\$25,300.00	\$25,300.00		
8	UNITARY FLEXIBLE POROUS MULCH	2,250	S.F.	\$17.00	\$38,250.00	\$15.50	\$34,875.00	\$16.42	\$36,945.00		
9	CONCRETE SIDEWALK, 4" THICK	30	S.Y.	\$105.00	\$3,150.00	\$153.00	\$4,590.00	\$135.00	\$4,050.00		
10	8"x18" CONCRETE VERTICAL CURB	60	L.F.	\$45.00	\$2,700.00	\$60.00	\$3,600.00	\$80.00	\$4,800.00		
TOTAL AMOUNT - ALTERNATE A, ITEMS 6 - 10:					\$89,800.00		\$116,143.00		\$73,595.00		
TOTAL AMOUNT FOR BOTH BASE AND ALTERNATE A :					\$287,700.00		\$349,328.00		\$255,591.00		
DOCUMENTATION											
Required Number of Copies (3):				Y/N	Yes	Y/N	No - 2	Y/N	Yes	Y/N	
Bid Deposit/Bond:				Y/N	Yes	Y/N	Yes	Y/N	Yes	Y/N	
Consent of Surety:				Y/N	Yes	Y/N	Yes	Y/N	Yes	Y/N	
Buy American Certification:				Y/N	Yes	Y/N	Yes	Y/N	Yes	Y/N	
Right to Extend - Time for Award:				Y/N	Yes	Y/N	Yes	Y/N	Yes	Y/N	
Statement of Ownership Disclosure:				Y/N	Yes	Y/N	Yes	Y/N	Yes	Y/N	
Non-Collusion Affidavit:				Y/N	Yes	Y/N	Yes	Y/N	Yes	Y/N	
Mandatory Equal Employment Opportunity Language:				Y/N	Yes	Y/N	Yes	Y/N	Yes	Y/N	
NJ Affirmative Action Regulation Compliance Notice:				Y/N	Yes	Y/N	Yes	Y/N	Yes	Y/N	
Required Subcontractors Listing:				Y/N	None - None Required	Y/N	None - None Required	Y/N	None -None Required	Y/N	None Required
Acknowledge of Receipt of Addenda:				Y/N	None Issued	Y/N	None Issued	Y/N	None Issued	Y/N	None Issued
Disclosure of Investment Activities in Iran Statement-Two Part Form:				Y/N	Yes	Y/N	Yes	Y/N	Yes	Y/N	
NJ Business Registration Certificate (BRC):				Y/N	Yes	Y/N	Yes	Y/N	Yes	Y/N	
NJ Business Registration Certificate for Subcontractors (BRC):				Y/N	N/A	Y/N	N/A	Y/N	N/A	Y/N	
NJ Public Works Contractors Registration Act Certificate:				Y/N	Yes	Y/N	Yes	Y/N	Yes	Y/N	
NJ Public Works Contractors Registration Act Certificate for Subcontractors:				Y/N	N/A	Y/N	N/A	Y/N	N/A	Y/N	
Statement of Authority:				Y/N	Yes	Y/N	Yes	Y/N	Yes	Y/N	
W-9:				Y/N	Yes	Y/N	Yes	Y/N	Yes	Y/N	



ADMINISTRATION

CITY OF OCEAN CITY

AMERICA'S GREATEST FAMILY RESORT

Emergency Management • Engineering and Construction • Humane Resource • Information Technology • Planning & Zoning • Purchasing

Memo

To: Joseph Clark, QPA, Purchasing Manager

From: Arthur J. Chew, PE, PP, CFM, CME, CPWM

CC:

Date: September 20, 2017

Re: Recommendation of Award - Contract 18-15 – Job # 5-2018-015

I have reviewed the qualifications and bid prices of Whirl Construction and find them acceptable. Within the City of Ocean City, they recently installed the playground equipment at 15th Street playground as well as the current project at 52nd Street playground. Their previous work has been generally acceptable and I have no objection with the contract being awarded to Whirl Construction.

This project includes the replacement of the playground equipment at the 8th Street playground and a portion of the playground equipment at North Street playground. The play surface for both sites is proposed to be a poured rubber play surface similar to the surface at the other City playgrounds. Also included in the 8th Street portion of the project is the replacement of the 2 basketball nets and backstops, and color coating the court surface.

At North Street, the piece of playground equipment for 5 to 12 year olds which was not replaced in the 2008 renovation will be replaced. The play area will be expanded to include another piece of playground equipment and then install a rubber play surface. Site work will also be included in the project for the installation of a seasonal restroom facility along the alley fence line. The restroom facility will be similar in fashion to the facility at the 15th Street playground.

AJC

\\OCESERVER\NetworkShare\Engineering\5-Public Facilities\Playgrounds\Various Playgrounds\5-2018-015 2018 Improvements to Various Playground Facilities\Letters\18-15 Recommendation to Award 17-09-20.doc

115 12th Street, OCEAN CITY, NJ 08226
PH: 609-399-6111 FAX: 609-525-2496

Printed on Recycled Paper

CITY OF OCEAN CITY
CAPE MAY COUNTY, NEW JERSEY

RESOLUTION

#4

**AUTHORIZING THE REJECTION OF BID PROPOSALS FOR CITY CONTRACT # 17-30,
CONSTRUCTION OF A SALT STORAGE FACILITY**

WHEREAS, specifications were authorized for advertisement by Resolution #17-53-228 on Thursday, August 10, 2017 for City Contract #17-30, Construction of a Salt Storage Facility; and

WHEREAS, the Notice to Bidders was advertised in the Ocean City Sentinel on August 23, 2017 the Notice to Bidders was posted on the City of Ocean City's website @ www.ocnj.us and the Invitation for Bid Proposals was distributed to thirty seven (37) prospective bidder(s) for City Contract #17-30, Construction of a Salt Storage Facility; and

WHEREAS, bid proposals were opened for City Contract #17-30, Construction of a Salt Storage Facility on Tuesday, September 12, 2017 and three (3) bid proposal was received per the attached Summary of Bid Proposals; and

WHEREAS, Lamont H. Czar, P.E., Czar Engineering, LLC; Brian S. Meyers, Czar Engineering, LLC; Arthur J. Chew, Assistant City Engineer, P.E., P.P., C.M.E., C.F.M., C.P.W.M; Joseph P. Berenato, Director of Public Works; Michael Rossbach, Manager of Environmental Operations; Jason J. Sieira, Manager of Capital Planning; Darleen H. Korup, Purchasing Assistant; Allison L. Hansen, Assistant Purchasing Agent and Joseph S. Clark, QPA, City Purchasing Manager have reviewed the bid proposals and specifications and determined that it is in the City's best interest to reject all bid proposals based on the bid proposals being over the engineer's estimate, the budgeted amount and the City's need to revise the specifications in accordance with N.J.S.A. 40A:11-13.2 (b) (d); and

NOW THEREFORE, BE IT RESOLVED by the City Council of the City of Ocean City, New Jersey that City Contract #17-30, Construction of a Salt Storage Facility be and is hereby rejected and rebid as stated above.

Peter V. Madden
Council President

FILES: REJ 17-30 Salt Storage Facility.doc

Offered by Seconded by

The above resolution was duly adopted by the City Council of the City of Ocean City, New Jersey, at a meeting of said Council duly held on the day of, 2017

NAME	AYE	NAY	ABSENT	ABSTAINED
Barr	_____	_____	_____	_____
Bergman	_____	_____	_____	_____
DeVlieger	_____	_____	_____	_____
Hartzell	_____	_____	_____	_____
McClellan	_____	_____	_____	_____
Madden	_____	_____	_____	_____
Wilson	_____	_____	_____	_____

.....
Melissa G. Bovera, City Clerk

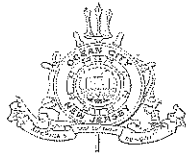

CITY OF OCEAN CITY

AMERICA'S GREATEST FAMILY RESORT

PURCHASING DIVISION
SUMMARY OF BID PROPOSALS

BY THE GOVERNING BODY OF THE CITY OF OCEAN CITY, NJ

DATE RECEIVED: Tuesday, September 12, 2017 @ 2:00 PM, EDT
CITY CONTRACT #: 17-30
PROPOSAL NAME: Construction of Salt Storage Facility

NAME, ADDRESS & BID OF EACH BIDDER		Levy Construction Company, Inc.	Fred M. Schiavone Construction, Inc.	Straga Brothers, Inc.					
Key: Engineer's Estimate:		134 Cuthbert Blvd.	P.O. Box 416	P.O. Box 216					
Control Estimate \$ 472,800.00		Audubon, NJ 08106	Malaga, NJ 08328	Glassboro, NJ 08028					
Owner's Allowance \$ 50,000.00		Simon Levy, President	Roberta M. Schiavone, Sec. Treas.	Dennis Straga, Vice President					
Total \$ 522,800.00		P: 856-547-0707	P: 856-697-4558	P: 856-881-7960					
		F: 856-547-2424	F: 856-697-9612	F: 856-881-8853					
		simon@levyconstuction.com	roberta@fmschiavone.com	dennis@stragabrothers.net					
1.1 OFFER:		UNIT							
A	Contract Sum	LUMP SUM	\$ 546,600.00	\$ 431,000.00	\$ 480,000.00				
B	Lump Sum of \$50,000.00	LUMP SUM	\$ 50,000.00	\$ 50,000.00	\$ 50,000.00				
C	Total Amount Bid, Base Bid, Items A & B:		\$596,600.00	\$481,000.00	\$530,000.00				
1.2 ADD ALTERNATES:									
A	Add Alternate No. 1: Electrical	LUMP SUM	\$ 20,600.00	\$ 27,000.00	\$ 14,600.00				
1.4 CONTRACT TIME:									
A	Number of Days in Which the Work will be Completed		100	180	60				
REQUIRED INFORMATION									
Required Number of Copies (3):		Y/N	Yes	Y/N	Yes	Y/N	Yes	Y/N	
Bid Deposit/Bond:		Y/N	Yes	Y/N	Yes	Y/N	Yes	Y/N	
Consent of Surety:		Y/N	Yes	Y/N	Yes	Y/N	Yes	Y/N	
Buy American Certification		Y/N	Yes	Y/N	Yes	Y/N	Yes	Y/N	
Right to Extend - Time for Award:		Y/N	Yes	Y/N	Yes	Y/N	Yes	Y/N	
Statement of Ownership Disclosure:		Y/N	Yes	Y/N	Yes	Y/N	Yes	Y/N	
Non-Collusion Affidavit:		Y/N	Yes	Y/N	Yes	Y/N	Yes	Y/N	
Mandatory Equal Employment Opportunity Language:		Y/N	Yes	Y/N	Yes	Y/N	Yes	Y/N	
NJ Affirmative Action Regulation Compliances Notice:		Y/N	Yes	Y/N	Yes	Y/N	Yes	Y/N	
(Electrical Required) Subcontractors Listing:		Y/N	Electrical - Yes 3	Y/N	Electrical - Yes 3	Y/N	Electrical - Yes 1	Y/N	Electrical
Acknowledge of Receipt of Addenda (None only a Clarification):		Y/N	Yes	Y/N	Yes	Y/N	Yes	Y/N	
Disclosure of Investment Activities in Iran Statement-Two Part Form:		Y/N	Yes	Y/N	Yes	Y/N	Yes	Y/N	
NJ Business Registration Certificate (BRC):		Y/N	Yes	Y/N	Yes	Y/N	Yes	Y/N	
NJ Business Registration Certificate for Subcontractors (BRC):		Y/N	Yes	Y/N	Yes	Y/N	Yes	Y/N	
NJ Public Works Contractors Registration Act Certificate:		Y/N	Yes	Y/N	Yes	Y/N	Yes	Y/N	
NJ Public Works Contractors Registration Act Certificate for Subcontractors:		Y/N	Yes	Y/N	Yes	Y/N	Yes	Y/N	
Statement of Authority:		Y/N	Yes	Y/N	Yes	Y/N	Yes	Y/N	
W-9:		Y/N	Yes	Y/N	Yes	Y/N	Yes	Y/N	

CITY OF OCEAN CITY
CAPE MAY COUNTY, NEW JERSEY

RESOLUTION

#5

**AUTHORIZING CHANGE ORDER #1 CITY CONTRACT #16-51 R-1,
2016 IMPROVEMENTS TO VARIOUS RECREATIONAL COURT FACILITIES**

WHEREAS, Specifications were authorized for advertisement by Resolution #16-52-278 on Tuesday, October 11, 2016 for City Contract #16-51, 2016 Improvements to Various Recreational Court Facilities; and

WHEREAS, the Notice to Bidders was advertised in the Press of Atlantic City on October 15, 2016 the Notice to Bidders was posted on the City of Ocean City's website @ www.ocnj.us and the Invitation for Bid Proposals was distributed to twenty-three (23) prospective bidder(s) for City Contract #16-51, 2016 Improvements to Various Recreational Court Facilities; and

WHEREAS, bid proposals were opened for City Contract #16-51, 2016 Improvements to Various Recreational Court Facilities on Tuesday, November 1, 2016 and one (1) bid proposal was received; and

WHEREAS, Arthur Chew, P.E., P.P., Assistant City Engineer; Matthew von der Hayden, Manager of Capital Projects; Darleen H. Korup, Purchasing Assistant; Allison L. Hansen, Assistant Purchasing Agent and Joseph S. Clark, QPA, City Purchasing Manager have reviewed the bid proposal and specifications and recommend that the bid proposal be rejected due to the bid being over the engineer's estimate and the budgeted amount in accordance to N.J.S.A. 40A:11-13.2 (a, b); and

WHEREAS, the City Council of the City of Ocean City rejected and authorized for re-advertised City Contract #16-51, 2016 Improvements to Various Recreational Court Facilities by Resolution #16-52-305 adopted on Thursday, November 10, 2016; and

WHEREAS, the Notice to Bidders was advertised in the Ocean City Sentinel on Wednesday, November 16, 2016 the Notice to Bidders was posted on the City of Ocean City's website @ www.ocnj.us and the Invitation for Bid Proposals was distributed to thirty-one (31) prospective bidder(s) for City Contract #16-51 R-1, 2016 Improvements to Various Recreational Court Facilities; and

WHEREAS, bid proposals were opened for City Contract #16-51 R-1, 2016 Improvements to Various Recreational Court Facilities on Tuesday, December 6, 2016 and three (3) bid proposals were received; and

WHEREAS, Arthur Chew, P.E., P.P., Assistant City Engineer; Matthew von der Hayden, Manager of Capital Projects; Darleen H. Korup, Purchasing Assistant; Allison L. Hansen, Assistant Purchasing Agent and Joseph S. Clark, QPA, City Purchasing Manager have reviewed the bid proposal and specifications and recommend that City Contract # 16-51 R-1, 2016 Improvements to Various Recreational Court Facilities be awarded to Command Company, Inc., the lowest responsible bidder; and

WHEREAS, the City Council of Ocean City, New Jersey awarded City Contract #16-51 R-1, 2016 Improvements to Various Recreational Court Facilities on December 22, 2016 by Resolution #16-52-344 to Command Company, Inc., 1318 Antwerp Avenue, Egg Harbor City, NJ 08215 in the amount of \$593,700.00; and

WHEREAS, Arthur J. Chew, PE, PP, CFM, CME, CPWM, Assistant City Engineer; Steven M. Longo, Manager of Public Buildings & Property; Jason J. Sieira, Manager of Capital Planning; Marcia R. Chew, Senior Accountant; Darleen H. Korup, Purchasing Assistant; Allison L. Hansen, Assistant Purchasing Agent and Joseph S. Clark, QPA, City Purchasing Manager have reviewed and certified Change Order #1 to City Contract #16-51 R-1, 2016 Improvements to Various Recreational Court Facilities is correct as follows:

CITY OF OCEAN CITY
CAPE MAY COUNTY, NEW JERSEY

RESOLUTION

Change Order #1

<u>Item</u>	<u>Description</u>	<u>Quantity</u>	<u>Unit Price</u>	<u>Total Price</u>
<u>Increases</u>				
1A	Repair crack on pickleball courts 18th Street	1 LS	\$ 6,267.00	\$ 6,267.00
1B	Acrylic binder repair of low areas 18th Street	1 LS	\$ 1,910.00	\$ 1,910.00
2A	Acrylic binder repair of low areas 52nd Street	1 LS	\$ 1,100.00	\$ 1,100.00
2B	Mobilization 52nd Street	1 LS	\$ 750.00	\$ 750.00
2C	Install owner supplied basketball poles 52nd Street	1 LS	\$ 4,800.00	\$ 4,800.00
2D	Remove existing poles 52nd Street	1 LS	\$ 1,900.00	\$ 1,900.00
2E	Four Coat Color System Basketball Surface	528 SY	\$ 12.00	<u>\$ 6,336.00</u>
Total Increases				\$ 23,063.00
Total Amount of Increases for Change Order #1.....				\$ 23,063.00
Total Amount of Change Order #1 to City Contract # 16-51 R-1, 2016 Improvements to Various Recreational Court Facilities.....				\$ 23,063.00
Total Amount of City Contract #16-51 R-1, 2016 Improvements to Various Recreational Court Facilities including Change Order #1.....				\$ 616,763.00

WHEREAS, the newly adjusted contract cost including Change Order #1 is \$616,763.00, an increase of \$23,063.00 to the original contract and a 3.885(%) percent increase the total for City Contract #16-51 R-1, 2016 Improvements to Various Recreational Court Facilities; and

NOW THEREFORE, BE IT RESOLVED by the City Council of the City of Ocean City, NJ that it authorizes Change Order #1 to City Contract #16-51 R-1, 2016 Improvements to Various Recreational Court Facilities in the amount of \$23,063.00 (PO #16-03723); and

BE IT FURTHER RESOLVED that the Director of Financial Management is authorized to process Change Order #1 in the amount of \$23,063.00 to City Contract #16-51 R-1, 2016 Improvements to Various Recreational Court Facilities (PO #16-03723) issued to Command Company, Inc., 1318 Antwerp Avenue, Egg Harbor City, NJ 08215 to be charged to the following Grant Account # G-02-40-181-200 - \$20,000.00 & Capital Account # C-04-55-294-307 - \$3,063.00.

CERTIFICATION OF FUNDS



 Frank Donato III, CMFO
 Director of Financial Management

 Peter V. Madden
 Council President

Files: RESCO#1 16-51 R-1 2016 Imprv to Rec Court Fac.doc

Offered by Secoded by

The above resolution was duly adopted by the City Council of the City of Ocean City, New Jersey, at a meeting of said Council duly held on the day of 2017

NAME	AYE	NAY	ABSENT	ABSTAINED
Barr	_____	_____	_____	_____
Bergman	_____	_____	_____	_____
DeVlieger	_____	_____	_____	_____
Hartzell	_____	_____	_____	_____
Madden	_____	_____	_____	_____
McClellan	_____	_____	_____	_____
Wilson	_____	_____	_____	_____

.....
 Melissa G. Bovera, City Clerk



CITY OF OCEAN CITY, ENGINEERING DIVISION
 2018 IMPROVEMENTS TO VARIOUS RECREATION COURT FACILITIES

CHANGE ORDER NO. 1
 FILE NO. 5-15-051

PURCHASE ORDER #
 16-03723

CONTRACTOR:
 COMMAND CO INC
 1318 ANATWERP AVENUE
 EGG HARBOR CITY

REASON FOR CHANGE:
 ADDITIONAL LINE ITEMS NECESSARY TO COMPLETE PROJECT

THE TIME PROVIDED FOR COMPLETION OF THIS PROJECT IS:
 X UNCHANGED, _____ INCREASED, _____ DECREASED, BY _____ CALENDAR DAYS.

UPON EXECUTION THIS DOCUMENT SHALL BECOME AN AMENDMENT TO THE CONTRACT.

TYPE OF CHANGE	ITEM #	DESCRIPTION	QTY	UNITS	UNIT PRICE	AMOUNT
UPPLEMENTAL						
					SUBTOTAL:	\$0.00
EXTRA	1A	Repair crack on pickleball courts 18th Street	1	LS	\$6,237.00	\$6,267.00
	1B	Acrylic binder repair of low areas 18th Street	1	LS	\$1,910.00	\$1,910.00
	2A	Acrylic binder repair of low areas 52nd Street	1	LS	\$1,100.00	\$1,100.00
	2B	Mobilization 52nd Street	1	LS	\$750.00	\$750.00
	2C	Install owner supplied basketball poles 52nd Street	1	LS	\$4,800.00	\$4,800.00
	2D	Remove existing poles 52nd Street	1	LS	\$1,900.00	\$1,900.00
	2E	Four Coat Color System Basketball Surface	528	SY	\$12.00	\$6,336.00
					SUBTOTAL:	\$23,063.00
REDUCTION						
					SUBTOTAL:	\$0.00

CHANGE ORDER SUMMARY

PREVIOUS CHANGE ORDERS			CURRENT CHANGE ORDER	
NO.	AMOUNT	REASON FOR CHANGE	TYPE OF CHANGE	TOTAL
1	\$23,063.00	ADDITIONAL LINE ITEMS NECESSARY TO COMPLETE PROJECT		

2
3
4
5
6
7
8
9
10

+ SUPPLEMENTAL	\$0.00
+ EXTRA	\$23,063.00
- REDUCTIONS	\$0.00
NET CONTRACT CHANGE THIS CHANGE ORDER	\$23,063.00

ORIGINAL CONTRACT AMOUNT	\$593,700.00
AMENDED CONTRACT AMOUNT	\$616,763.00
TOTAL CONTRACT CHANGE (AMOUNT)	\$23,063.00
TOTAL CONTRACT CHANGE (PERCENT)	3.88%

ACCEPTED BY:

COMMAND CO INC

9/12/17
DATE

APPROVED BY:

PROJECT MANAGER

DATE

MUNICIPAL ENGINEER

DATE

PURCHASING AGENT

DATE

CHIEF FINANCIAL OFFICER

DATE

2			+ SUPPLEMENTAL	\$0.00
3			+ EXTRA	\$23,063.00
4			- REDUCTIONS	\$0.00
5			NET CONTRACT CHANGE	
6			THIS CHANGE ORDER	\$23,063.00
7				
8				
9				
10				

ORIGINAL CONTRACT AMOUNT	\$593,700.00
AMENDED CONTRACT AMOUNT	\$616,763.00
TOTAL CONTRACT CHANGE (AMOUNT)	\$23,063.00
TOTAL CONTRACT CHANGE (PERCENT)	3.88%

ACCEPTED BY: _____ DATE _____

APPROVED BY: _____ DATE _____

PROJECT MANAGER _____ DATE _____

MUNICIPAL ENGINEER _____ DATE _____

9/12/17

PURCHASING AGENT DATE _____

CHIEF FINANCIAL OFFICER DATE _____

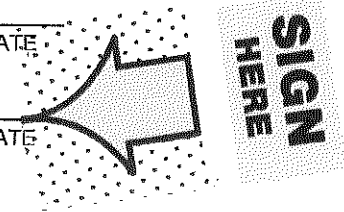

CITY OF OCEAN CITY
CAPE MAY COUNTY, NEW JERSEY

RESOLUTION

#6

**AUTHORIZING CHANGE ORDER #1, FINAL ACCEPTANCE & FINAL PAYMENT OF
CITY CONTRACT #15-23, 10TH STREET BULKHEAD IMPROVEMENTS**

WHEREAS, specifications were authorized for advertisement by Resolution #15-51-076 on March 26, 2015 for City Contract #15-23, 10th Street Bulkhead Improvements; and

WHEREAS, the Notice to Bidders was advertised in the Ocean City Sentinel on Wednesday, April 1, 2015, the Notice to Bidders was posted on the City of Ocean City's website, www.ocnj.us and Invitation for Bid Proposals were distributed to nine (9) prospective bidder(s); and

WHEREAS, bid proposals were opened for City Contract #15-23, 10th Street Bulkhead Improvements on Tuesday, April 28, 2015 and two (2) bid proposals were received; and

WHEREAS, Roger D. McLarnon, P.E., P.P., C.M.E., C.F.M., C.P.W.M., Director of Community Operations; Arthur Chew, P.E., Assistant City Engineer; Roger Rinck, Manager Specialist; Mathew von der Hayden, Manager of Capital Planning; Dorothy F. McCrosson, Esq., City Solicitor; Darleen H. Korup, Purchasing Assistant and Joseph S. Clark, QPA, City Purchasing Manager reviewed the two (2) bid proposals and specifications and recommended that the contract be awarded to Walters Marine Construction, Inc., the lowest responsible bidder; and

WHEREAS, the City Council of Ocean City, New Jersey awarded City Contract #15-23, 10th Street Bulkhead Improvements on May 14, 2015 by Resolution #15-51-120 in the amount of \$254,545.00; and

WHEREAS, Arthur Chew, P.E., Assistant City Engineer; Roger Rinck, Manager Specialist; Marcia R. Chew, Senior Accountant; Jason L. Sieira, Manager of Capital Planning; Darleen H. Korup, Purchasing Assistant; Allison L. Hansen, Assistant Purchasing Agent and Joseph S. Clark, QPA, City Purchasing Manager have reviewed and certified that all work has been completed in accordance with the job specifications and that the Maintenance Bond, Release of Liens, Application for Final Payment and Certified Payrolls have been submitted and are in proper order and certified Change Order #1 for City Contract #15-23, 10th Street Bulkhead Improvements are correct as follows:

Change Order #1

Increase

<u>Item</u>	<u>Description</u>	<u>Quantity</u>	<u>Unit Price</u>	<u>Total Price</u>
Extras				
COR1.	OCP Insurance Invoice	1 Lump Sum	\$ 504.50	\$ 504.50
COR2.	Additional Materials Line	1 Lump Sum	\$ 2,046.00	\$ 2,046.00
Total Amount of Extras				\$ 2,550.50
Total Amount of Increases for Change Order #1				\$ 2,550.50

Decrease

Reductions

13.	35' Pilings, Class B	10 Units	\$ 1,200.00	(\$ 12,000.00)
14.	Fishing Pier	1,180 SF	\$ 16.00	(\$ 18,880.00)
15.	Aluminum 1½" Pipe Railing-2-Rail	6 LF	\$ 100.00	(\$ 600.00)
Total Amount of Reductions				(\$ 31,480.00)
Total Amount of Decreases for Change Order #1				(\$ 31,480.00)
TOTAL AMOUNT OF CHANGE ORDER #1.....				(\$ 28,929.50)

CITY OF OCEAN CITY
CAPE MAY COUNTY, NEW JERSEY

RESOLUTION

WHEREAS, the new adjusted contract cost including Change Order #1 is \$225,615.50, a (\$28,929.50) decrease which is a 11.37% percent decrease to the original contract total for City Contract #15-23, 10th Street Bulkhead Improvements; and

NOW THEREFORE, BE IT RESOLVED by the City Council of the City of Ocean City, NJ that it authorizes Change Order #1, Final Acceptance and Final Payment to City Contract #15-23, 10th Street Bulkhead Improvements (PO #15-01270); and

BE IT FURTHER RESOLVED that the Director of Financial Management is authorized to process Change Order #1 in the amount of (\$28,929.50) and final payment of City Contract #15-23, 10th Street Bulkhead Improvements (PO #15-01270) issued to Walters Marine Construction, Inc., 414 Woodbine-Oceanview Road, Ocean View, NJ 08230 in the amount of \$4,512.31 to be charged to Capital Account #C-04-55-281-101 - \$4,512.31 (PO#15-01270 Balance).

CERTIFICATION OF FUNDS



Frank Donato III, CMFO
Director of Financial Management

Peter V. Madden
Council President

FILES: RESCO#1FAFP15-23 10th St Bulkhead.doc

Offered by Seconded by

The above resolution was duly adopted by the City Council of the City of Ocean City, New Jersey, at a meeting of said Council duly held on the day of 2017

NAME	AYE	NAY	ABSENT	ABSTAINED
Barr	_____	_____	_____	_____
Bergman	_____	_____	_____	_____
DeVlieger	_____	_____	_____	_____
Hartzell	_____	_____	_____	_____
Madden	_____	_____	_____	_____
McClellan	_____	_____	_____	_____
Wilson	_____	_____	_____	_____

.....
Melissa G. Bovera, City Clerk



CITY OF OCEAN CITY

AMERICA'S GREATEST FAMILY RESORT

ENGINEERING DIVISION

MEMORANDUM

To: Joseph Clark, Purchasing Manager
From: Roger Rinck, Project Manager
Date: September 14, 2017
RE: **FINAL ACCEPTANCE AND CLOSEOUT**
10th STREET BULKHEAD IMPROVEMENTS
Project #: 2-2015-023

The above referenced contract is complete. The Contractor's Maintenance Bond, Release of Liens, Payment of Debts and Claims and Consent of Surety to Final Payment, have been received. Final acceptance of the contract is requested for the September 28, 2017 Council Meeting.

Final payment is due in accordance with the attached contractor invoice and final change order.

If you have any questions, please feel free to contact me.

\\OCESERVER\NetworkShare\Engineering\FORMS-BLANKS\Close-out documents\Close out memo.doc



**CITY OF OCEAN CITY
ENGINEERING DIVISION
PAYMENT CERTIFICATE**

Certificate No. 4

PO No.: 15-01270
Project: 10TH STREET BULKHEAD IMPROVEMENTS

Contractor: WALTERS MARINE CONSTRUCTION INC
414 WOODBINE OCEAN VIEW ROAD
OCEAN VIEW NJ 08230

File No.:

ITEM NO.	ITEM DESCRIPTION	CONTRACT QTY	UNITS	UNIT PRICE	CONTRACT AMOUNT	QTY COMPL CERT #4	AMOUNT PAYABLE CERT # 4	TOTAL QTY COMPL	% COMPL	OVERAGE (paid at closeout)	TOTAL AMOUNT PAYABLE	
1	Soil Erosion and Sediment Control	1	LS	\$500.00	\$500.00		\$0.00	1	100.00%	\$0.00	\$500.00	
2	Maintenance and Protection of Traffic	1	LS	\$500.00	\$500.00		\$0.00	1	100.00%	\$0.00	\$500.00	
3	1-5 Soil Aggregate	225	CY	\$35.00	\$7,875.00		\$0.00	225	100.00%	\$0.00	\$7,875.00	
4	Dense Graded Aggregate Base Course, 6" Thick	140	SY	\$12.00	\$1,680.00	0	\$0.00	140	100.00%	\$0.00	\$1,680.00	
5	Hot Asphalt Surface Course, Mix 19M64, 3" Thick	140	SY	\$35.00	\$4,900.00	0	\$0.00	140	100.00%	\$0.00	\$4,900.00	
6	Composite Bulkhead	1	LS	\$117,000.00	\$117,000.00	0	\$0.00	1	100.00%	\$0.00	\$117,000.00	
7	6" x 18" Concrete Vertical Curb	70	LF	\$40.00	\$2,800.00		\$0.00	70	100.00%	\$0.00	\$2,800.00	
8	Concrete Driveway 4" Thick	15	SY	\$75.00	\$1,125.00		\$0.00	15	100.00%	\$0.00	\$1,125.00	
9	Concrete Driveway, 6" Thick	13	SY	\$100.00	\$1,300.00		\$0.00	13	100.00%	\$0.00	\$1,300.00	
10	Resel Existing Casting	1	UNIT	\$12,000.00	\$12,000.00		\$0.00	1	100.00%	\$0.00	\$12,000.00	
11	Signs	7	SF	\$75.00	\$525.00		\$0.00	7	100.00%	\$0.00	\$525.00	
12	Site Restoration	1	LS	\$2,500.00	\$2,500.00		\$0.00	1	100.00%	\$0.00	\$2,500.00	
13	35' Plings, Class B	25	UNIT	\$1,200.00	\$30,000.00		\$0.00	25	100.00%	\$0.00	\$30,000.00	
14	Fishing Pier	1,450	SF	\$16.00	\$23,360.00		\$0.00	1,450	100.00%	\$0.00	\$23,360.00	
15	Aluminum 1-1/2" Pipe Railing-2 Rail	70	LF	\$100.00	\$7,000.00		\$0.00	70	100.00%	\$0.00	\$7,000.00	
16	ADA Ramp	1	LS	\$10,000.00	\$10,000.00		\$0.00	1	100.00%	\$0.00	\$10,000.00	
17	Insurance	1	LS	\$504.50	\$504.50		\$0.00	1	100.00%	\$504.50	\$504.50	
18	Additional Materials	1	LS	\$2,046.00	\$2,046.00		\$0.00	1	100.00%	\$2,046.00	\$2,046.00	
Summary							Subtotals:			\$0.00	\$2,550.50	\$225,615.50

Change Orders				Previous Payments				
No.	Description	Amount	Percent	No.	Amount	No.	Amount	
1	ADDITIONAL ITEMS NEEDED TO COMPLETE PROJECT	-\$28,929.50	-11.37%	1	\$108,461.50	9		
2				2	\$56,546.00	10		
3				3	\$56,095.69	11		
4				4		12		
5				5		13		
6				6		14		
7				7		15		
8				8		16		
Total		(\$28,929.50)	-11.37%	Total		Total		\$221,103.19

Contract Information		Payment Information	
Original Contract Amount	\$254,545.00	Total Amount Complete	\$225,615.50
Contract Change (Amount)	(\$28,929.50)	Loss Overage	\$0.00
Contract Change (Percent)	-11.37%	Less Retained 2%	\$0.00
Amended Contract Amount	\$225,615.50	Less Penalties (none at this time)	\$0.00
		Sub Total	\$225,615.50
		Less Amount Previously Paid	\$221,103.19

Date Notice to proceed issued: 1/0/1900
 Calendar Day Completion Time: 0
 Approved Calendar Day Extension:
 Contract Completion Date: 1/0/1900

The contractor's signature below is his assurance to the City, concerning payment herein applied for, that:
 (1) the Work has been performed as required in the Contract Documents.
 (2) all sums previously paid to Contractor under this Contract have been used to pay Contractor's costs for labor, materials and other obligations under the Contract and
 (3) the Contractor is legally entitled to this payment.

[Signature]
 Project Manager Date
 Municipal Engineer Date

[Signature]
 Contractor's Signature Date
David E. Southard
 Secretary

\$4,512.31
 PAYMENT REQUEST



CITY OF OCEAN CITY, ENGINEERING DIVISION
10TH STREET BULKHEAD IMPROVEMENTS

CHANGE ORDER NO. 1
FILE NO. 2-15-023

PURCHASE ORDER #
15-01270

CONTRACTOR:
WALTERS MARINE CONSTRUCTION INC
414 WOODBINE OCEAN VIEW ROAD
OCEAN VIEW NJ 08230

REASON FOR CHANGE:
ADDITIONAL ITEMS NEEDED TO COMPLETE PROJECT

THE TIME PROVIDED FOR COMPLETION OF THIS PROJECT IS:
___ UNCHANGED, ___ INCREASED, ___ DECREASED, BY ___ CALENDAR DAYS.

UPON EXECUTION THIS DOCUMENT SHALL BECOME AN AMENDMENT TO THE CONTRACT.

TYPE OF CHANGE	ITEM #	DESCRIPTION	QTY	UNITS	UNIT PRICE	AMOUNT
SUPPLEMENTAL						
					SUBTOTAL:	\$0.00
EXTRA	COR1	OCP INSURANCE INVOICE	1	LS	\$504.50	\$504.50
	COR2	ADDITIONAL MATERIALS LINE	1	LS	\$2,046.00	\$2,046.00
					SUBTOTAL:	\$2,550.50
REDUCTION	13	35' Pilings, Class B	10	UNIT	\$1,200.00	\$12,000.00
	14	Fishing Pier	1180	SF	\$16.00	\$18,880.00
	15	Aluminum 1-1/2" Pipe Railing-2 Rail	6	LF	\$100.00	\$600.00
					SUBTOTAL:	\$31,480.00

CHANGE ORDER SUMMARY

PREVIOUS CHANGE ORDERS			CURRENT CHANGE ORDER	
NO.	AMOUNT	REASON FOR CHANGE	TYPE OF CHANGE	TOTAL
1	(\$28,929.50)	ADDITIONAL ITEMS NEEDED TO COMPLETE PROJECT		
2			+ SUPPLEMENTAL	\$0.00
3				

4
5
6
7
8
9
10

+ EXTRA	\$2,550.50
- REDUCTIONS	\$31,480.00
NET CONTRACT CHANGE THIS CHANGE ORDER	(\$28,929.50)

ORIGINAL CONTRACT AMOUNT \$254,545.00
AMENDED CONTRACT AMOUNT \$225,615.50
TOTAL CONTRACT CHANGE (AM) (\$28,929.50)
TOTAL CONTRACT CHANGE (PEI) -11.37%

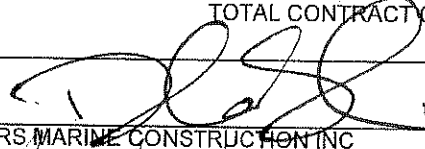
ACCEPTED BY:  **David E. Southard**
WALTERS MARINE CONSTRUCTION INC 8/31/12 Secretary
DATE

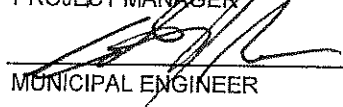
APPROVED BY:  PROJECT MANAGER _____ DATE _____
 MUNICIPAL ENGINEER _____ DATE _____
PURCHASING AGENT _____ DATE _____
CHIEF FINANCIAL OFFICER _____ DATE _____

CITY OF OCEAN CITY
CAPE MAY COUNTY, NEW JERSEY

RESOLUTION

#7

**SUPPORTING CAPE MAY COUNTY'S CONSTRUCTION
OF A SHARED USE PATH**

WHEREAS, Ocean City is known as a model bicycle friendly shore town through their investment into bicycle facilities over the years; and

WHEREAS, several recent construction projects such as the reconstruction of NJ Route 52 Causeway and the construction of the new Garden State Parkway Bridge over Great Egg Harbor Bay, has greatly expanded the accessibility of pedestrians and bicyclists in the region, particularly in southern Atlantic County and northern Cape May County; and

WHEREAS, the Roosevelt Boulevard (County Road No. 623) Bridge over Crook Horn Creek is the southern access point that connects Ocean City with Marmora in Upper Township and this bridge does see bicycle and pedestrian use despite not meeting minimum requirements for pedestrian and bicycle compatibility; and

WHEREAS, this major bridge crossing is a missing link in the connectivity of miles of bicycle safe routes in and around Cape May and Atlantic Counties; and

WHEREAS, the Board of Chosen Freeholders of the County of Cape May proposes to construct a shared use (pedestrian/bicycle) path along Roosevelt Boulevard (CR623) over Crook Horn Creek between the Marmora section of Upper Township and Ocean City; and

WHEREAS, has the County has applied for a grant to New Jersey Department of Transportation Regional Transportation Alternatives Program to fund the project.

NOW, THEREFORE BE IT RESOLVED, by the City of Ocean City, that the City of Ocean City fully endorses and fully supports the County's plans to construct a shared use (pedestrian/bicycle) path along Roosevelt Boulevard (CR623) over Crook Horn Creek between the City and the Marmora section of Upper Township.

Peter V. Madden
Council President

Offered by Seconded by

The above resolution was duly adopted by the City Council of the City of Ocean City, New Jersey, at a meeting of said Council duly held on the day of 2017.

NAME	AYE	NAY	ABSENT	ABSTAINED
Barr	_____	_____	_____	_____
Bergman	_____	_____	_____	_____
DeVlieger	_____	_____	_____	_____
Hartzell	_____	_____	_____	_____
Madden	_____	_____	_____	_____
McClellan	_____	_____	_____	_____
Wilson	_____	_____	_____	_____

.....
City Clerk

CITY OF OCEAN CITY
CAPE MAY COUNTY, NEW JERSEY

RESOLUTION

#8

**APPROVING TAX OVERPAYMENT REFUNDS
2017-15 THRU 2017-17**

WHEREAS, the Tax Collector has certified and issued refund vouchers to the following tax payers who overpaid their taxes.

NOW, THEREFORE BE IT RESOLVED, by the City Council of the City of Ocean City that authorization for refund be approved as per the attached schedule.

DESCRIPTION

<u>VOUCHER</u>	<u>NAME</u>	<u>BLOCK/LOT/QUAL.</u>	<u>AMOUNT</u>	<u>YEAR</u>
2017-15	CORELOGIC	8/16	\$1,477.80	2017
2017-16	CORELOGIC	1602/4/C1637	\$ 74.45	2017
2017-17	CORELOGIC	901/11/C2	\$ 737.83	2017
Total			\$ 2,290.08	

Peter V. Madden
Council President

Offered by Seconded by

The above resolution was duly adopted by the City Council of the City of Ocean City, New Jersey, at a meeting of said Council duly held on the day of 2017.

NAME	AYE	NAY	ABSENT	ABSTAINED
Barr	_____	_____	_____	_____
Bergman	_____	_____	_____	_____
DeVlieger	_____	_____	_____	_____
Hartzell	_____	_____	_____	_____
Madden	_____	_____	_____	_____
McClellan	_____	_____	_____	_____
Wilson	_____	_____	_____	_____

.....
City Clerk

CITY OF OCEAN CITY
CAPE MAY COUNTY, NEW JERSEY

RESOLUTION

#9

**CERTIFYING THE GOVERNING BODY HAS REVIEWED THE
BEST PRACTICES INVENTORY QUESTIONNAIRE**

WHEREAS, the State of New Jersey 2012 Appropriations Act (P.L. 2012, c.18) requires the Division of Local Government Services to determine how much of each municipality's final 5% allocation of state aid will be disbursed based upon the results of a Best Practices Inventory; and

WHEREAS, this Inventory is a constructive way for the City to consider and embrace a range of best practices that will help improve financial accountability and transparency; and

WHEREAS, the Best Practices Inventory Questionnaire was prepared by the Chief Financial Officer of the City.

NOW, THEREFORE, BE IT RESOLVED by the City Council of the City of Ocean City, New Jersey that Council has reviewed the 2017 Best Practices Inventory Questionnaire and requests the Municipal Clerk to submit the Best Practices Public Meeting Certification Form to the New Jersey Department of Community Affairs, Division of Local Government Services.

Peter V. Madden
Council President

Offered by Seconded by

The above resolution was duly adopted by the City Council of the City of Ocean City, New Jersey, at a meeting of said Council duly held on the day of 2017.

NAME	AYE	NAY	ABSENT	ABSTAINED
Barr	_____	_____	_____	_____
Bergman	_____	_____	_____	_____
DeVlieger	_____	_____	_____	_____
Hartzell	_____	_____	_____	_____
Madden	_____	_____	_____	_____
McClellan	_____	_____	_____	_____
Wilson	_____	_____	_____	_____

.....
City Clerk

Best Practices Worksheet CY 2017/SFY2018

Ocean City City (Cape May)		
0508	Please see Color Key at bottom of sheet for limits on answers	
Answer	Question	Comments
Yes	N.J.S.A. 34:13A-8.2 requires public employers, including municipalities, to file with the Public Employment Relations Commission (PERC) a copy of all contracts negotiated with public employee representatives. This includes, but is not limited to, collective bargaining agreements, memoranda of understanding, contract amendments, and "side letter" or "side bar" agreements. Copies of same may be emailed to contracts@perc.state.nj.us. Has your municipality filed all current contracts with PERC?	
Yes	Has your municipality adopted a written vehicle use policy prohibiting personal use of municipal vehicles (except for commuting), and providing that employees authorized to use such vehicles for commuting to/from work have a fringe benefit value added to the gross income reported on the employee's W-2 (unless the vehicle meets the "qualified non-personal vehicle" criteria specified by the IRS)? Only answer "N/A" if your municipality does not have any municipally-owned vehicles.	
Yes	Active monitoring management of a municipality's ratable base is fundamental to helping ensure fiscal stability. There should be communication with the municipal tax assessor to ensure that the municipality has sufficient time to factor potential exposure to tax appeal judgements into their budgetary planning. <u>Does your municipality have an established written policy requiring its tax assessor to notify the chief financial officer and the governing body of all tax appeals upon filing, but no later than June 1st each year?</u> The policy should, at minimum, require the assessor's report to break down by property class the number of pending appeals, the current assessed value, and the reduction in assessed value if all appeals were successful. If there are appeals for which complete information is unavailable as of June 1, those appeals should be reported as information becomes available. Only answer "N/A" if your municipality is in Gloucester County (county assessor pilot program) or participates in the Monmouth County assessment demonstration program.	

Best Practices Worksheet CY 2017/SFY2018

Ocean City City (Cape May)			
0508	Please see Color Key at bottom of sheet for limits on answers		
Answer	Question	Comments	
4 Yes	Does your municipality maintain an up-to-date municipal website containing at minimum the following: past three years adopted budgets; the current year's proposed budget (including the full adopted budget for the current year when approved by the governing body); most recent annual financial statement and audits; notification(s) for solicitation of bids and RFPs; and meeting dates, minutes and agendas for the governing body, planning board, board of adjustment and all commissions?		
N/A	The "Director's Ratio" (the average ratio of assessed to true market value) for each municipality as determined by the Director of the Division of Taxation, in the Table of Equalized Valuations promulgated annually pursuant to <u>N.J.S.A. 54:1-35.1</u> . A Director's Ratio of lower than 85 percent generally denotes lack of uniformity in assessments and indicates a need for revaluation. <u>N.J.A.C. 18:12A-1.14</u> . <u>If the ratio of assessed values to market values in your municipality is presently less than 85%, has your municipality at minimum awarded a contract for the updating of tax maps and earmarked funds in its budget for the hiring of relevant firms and/or professionals?</u>		
6 Yes	The Local Government Ethics Law, designed to ensure transparency in government, requires local government officers to file Financial Disclosure Forms. Compliance by local elected officials is particularly important. <u>Have all of your local elected officials filed their Financial Disclosure Form in 2017 that covers the 2016 calendar year?</u>		
7 Yes	While outside employment by municipal officials can sometimes be acceptable, it is imperative that no conflicts of interest impinge on municipal governance. Does your municipality have 1) an established documented process requiring department heads to submit notice of outside employment, and 2) upon receiving such notice, does your municipality have a documented process within its human resources function to determine whether or not a conflict of interest exists?		

Best Practices Worksheet CY 2017/SFY2018

Ocean City City (Cape May)			
0508		<i>Please see Color Key at bottom of sheet for limits on answers</i>	
Answer	Question	Comments	
N/A	<p>Many municipalities have created one or more authorities (including fire districts, utilities authorities, redevelopment authorities, housing authorities, port authorities, etc.) to provide greater focus and attention on addressing a public need, or to reduce governing body burdens. While creation of an authority is often appropriate, and many authorities successfully fulfill their missions, authorities with weak membership or insufficient local-level monitoring can become wasteful, inefficient and unresponsive to the public they serve. N.J.S.A. 40A:5A-20 allows a local governing body to dissolve an authority subject to certain parameters and with Local Finance Board approval. Municipalities should at least annually assess the authority or authorities they created and publicly discuss their findings and conclusions. Findings and conclusions should address whether their existing authorities 1) continue to serve the public interest, and 2) are more efficient than other potential alternatives in providing services and financing public facilities. <u>Within the past year, 1) has the above-referenced discussion appeared as a listed agenda item on a scheduled governing body meeting, and 2) do the findings and conclusion appear in publicly-available meeting minutes?</u> Please identify the meeting date under "Comments"</p>	The City does not have any authorities.	
N/A	<p>Audit findings address areas needing improvement. Ignoring these findings devalues the process; therefore, municipalities should correct noted deficiencies. <u>Have all audit findings from the 2015 audit been 1) identified in the corrective action plan and 2) addressed such that they are not repeated in the 2016 audit?</u> If the answer is no, please list the repeat findings, along with the date the corrective action plan was submitted to DLGS, under Comments. Only answer "N/A" if there were no audit findings in 2014.</p>		
Yes	<p>Payments In Lieu of Taxed (PILOTs) are often used as a tool for economic development. It is imperative that municipalities monitor PILOT agreements to ensure recipients complying with all agreement terms, including but not limited to timely payment and reporting. Does your municipality 1) have an official designated to monitor exemptions granted pursuant to the Long-Term Tax Exemption Law (N.J.S.A. 40A:20-1 et seq.) and Five-Year Exemptions/ Abatements granted pursuant to N.J.S.A. 40A:21-1 et seq., and 2) have in place a documented process for ensuring compliance with the terms of each PILOT agreement?</p>		

Best Practices Worksheet CY 2017/SFY2018

Ocean City City (Cape May)		
0508	Please see Color Key at bottom of sheet for limits on answers	
Answer	Question	Comments
11 Yes	N.J.S.A. 40A:5-4 requires municipalities to complete their annual audit for the preceding fiscal year within 6 months after the close of their fiscal year. Further, N.J.S.A. 40A:5-6 requires the municipality's auditor to submit a certified duplicate copy of the audit report and recommendations with the Division within 5 days after filing the original with the municipal clerk. <u>Has your municipality received its completed audit for the preceding fiscal year within the statutory timeframe, and confirmed that your auditor has filed a certified duplicate copy of the audit report with the Division?</u> You may only answer this question "N/A" if the Director expressly granted an extension in response to a governing body resolution petitioning for same.	
12 Yes	Pursuant to N.J.S.A. 40A: 2-40, the chief financial officer each municipality shall, before the end of the first month of the fiscal year, file its Annual Debt Statement with the Division of Local Government Services. The annual debt statement must be filed electronically following the procedure described in Local Finance Notice 2013-3. <u>Did your municipality file its electronic Annual Debt Statement for the preceding fiscal year with the Division no later than January 31 (July 31 for SFY municipalities)?</u>	
13 Yes	While the issuance and renewal of bond anticipation notes can be a reasonable and prudent financing mechanism, failing to take advantage of low interest rates on permanent financing can cause municipalities to incur unnecessary carrying costs and inflated costs of issuance. Has your municipality evaluated its outstanding bond anticipation notes and developed a strategy to move toward permanent financing?	

Best Practices Worksheet CY 2017/SFY2018

Ocean City City (Cape May)			
0508	Please see Color Key at bottom of sheet for limits on answers		
Answer	Question	Comments	
14 Yes	Pursuant to <u>N.J.S.A. 40A:11-25</u> , the Director of the Division of Local Government Services must approve all prequalification regulations enacted by contracting units subject to the Local Public Contracts Law. Prequalification requirements can be fixed according to experience, financial ability, capital, and equipment. Absent Director approval, bid prequalification regulations are of no force and effect and may not be required as a condition of bid acceptance on any public contract. Local Finance Notice 2016-12 goes into further detail concerning prequalification regulations under the Local Public Contracts Law. Is your municipality following the process set forth in <u>N.J.S.A. 40A:11-25</u> , including seeking Director approval prior to implementing and enforcing all prequalification regulations? “N/A” is only applicable where the municipality has not adopted any prequalification regulations.		
15 Yes	<u>N.J.A.C. 5:30-3.8(a)</u> requires that the introduced annual municipal budget incorporate a User-Friendly Budget section. Is your municipality providing the public with its introduced User-Friendly Budget at least one week prior to the date of the public hearing on adopting the annual budget?		
16 Yes	Unless the Director sets forth a later date pursuant to <u>N.J.S.A. 40A:4-5.1</u> , <u>N.J.S.A. 40A:4-5</u> requires that calendar year municipalities approve their introduced budgets no later than February 10 (or August 10 for state fiscal year municipalities) and <u>N.J.S.A. 40A:4-10</u> requires that calendar year municipalities adopt their budgets no later than March 20 (or September 20 for state fiscal year municipalities). <u>Did your municipality introduce and adopt its current year budget no later than the dates provided by law or as extended by the Director in Local Finance Notice 2016-20?</u> This question may only be answered N/A if your municipality is under State Supervision or if the Division instructed the municipality to delay budget adoption.		

Best Practices Worksheet CY 2017/SFY2018

Ocean City City (Cape May)			
0508	Please see Color Key at bottom of sheet for limits on answers		
Answer	Question	Comments	
17	Yes	Does your municipality exclude from healthcare coverage part-time elected and appointed officials (less than 35 hours per week)? Only answer "yes" if no part-time elected or appointed officials receive health benefits. If your municipality has part-time elected or appointed officials who elect to take State Health Benefits Program (SHBP) health benefits (or receive a waiver for not doing so) by virtue of serving in their position continuously since May 21, 2010, you must answer "No". If you answered "No", please list in the Comments section the name and title of each elected or appointed official receiving either health benefits or a waiver payment in lieu of health benefits.	
18	Yes	Is your municipality collecting at least the amount set forth by the Chapter 78 Grid for health benefit contributions (or 1.5% of base salary, whichever is greater) for all officers and employees?	
19	Yes	Payments for waivers filed before May 21, 2010, and maintained continuously since, cannot exceed fifty percent (50%) of the amount saved by the local unit as a result of the employee's waiver of coverage. For waivers filed on or after May 21, 2010, which is the effective date of P.L. 2010, c. 2, payments cannot exceed the lesser of twenty-five percent (25%) of the amount saved by the local unit as a result of the waiver, or \$5,000. When calculating an employee's waiver payment, the local unit must deduct the employee's healthcare contribution obligation from the total premium cost. Local units have sole discretion as to whether or not to offer employees payments for waiver of health benefits, and may offer waiver payments lower than the statutory maximum. Health benefit waiver payments are statutorily excluded from collective bargaining. See Local Finance Notices 2010-12 and 2016-10 for further discussion on health benefit waiver payments. <u>Does your municipality 1) refrain from paying waiver payments in excess of the statutory maximum; 2) deduct employee healthcare contribution obligations from the total premium cost when calculating waiver payments; and 3) refrain from incorporating healthcare waiver payments in any labor agreement?</u> "N/A" is only applicable where the municipality has a policy of not making payments in lieu of health benefits.	

Best Practices Worksheet CY 2017/SFY2018

Ocean City City (Cape May)			
0508		<i>Please see Color Key at bottom of sheet for limits on answers</i>	
Answer	Question	Comments	
20	Yes	The Fair Labor Standards Act (FLSA) is a federal law requiring that overtime pay must be paid for all hours over 40 hours in a work week except for those employees classified as exempt and thus not entitled to overtime. Management employees such as elected officials, managers/administrators, municipal clerks, CFOs, public works superintendents, police chiefs and other department heads are typically classified as having exempt status and thus not entitled to overtime pay. Other municipal employees may also be classified as exempt under the FLSA (you should consult with labor counsel for more detailed guidance). Exempt status would also preclude overtime pay for time worked during emergencies, attendance at night meetings and participation in training sessions. Compensated leave time in lieu of cash payments is considered to be a form of overtime pay unless such leave is utilized in the same pay period. <u>Does your municipality refrain from paying overtime to employees classified as exempt under the FLSA?</u>	
21	No	<u>For any employees covered by a collective bargaining agreement, has your municipality instituted a policy to not compensate said employees for sick leave accumulated after a certain date?</u> If such provisions were imposed by an arbitrator in binding arbitration but the municipality is seeking to eliminate such a contractual obligation through collective bargaining, your answer can be "N/A". If answering "N/A", the municipality must identify under "Comments" each such provision imposed by an arbitrator, along with the status of the collective bargaining negotiations to eliminate each such provision.	
22	No	Has your municipality instituted a written policy to not compensate non-union employees for sick leave accumulated after a certain date?	
23	Yes	Has your municipality adopted an ordinance, resolution, regulation or written policy eliminating longevity awards, bonuses or payments for non-union employees?	

Best Practices Worksheet CY 2017/SFY2018

Ocean City City (Cape May)		
0508	<i>Please see Color Key at bottom of sheet for limits on answers</i>	
Answer	Question	Comments
No	<p>For any employees covered by a collective bargaining agreement, has your municipality <u>eliminated all longevity awards, bonuses or payments for employees hired on or after a specified date, and refrained from increasing any longevity awards, bonuses or payments for employees hired before a specified date?</u> The answer to this question can be "N/A" if such provisions were imposed by an arbitrator in binding arbitration but the municipality is seeking to eliminate such a contractual obligation through collective bargaining. If answering "N/A", the municipality must identify under "Comments" each such provision imposed by an arbitrator, along with the status of the collective bargaining negotiations to eliminate each such provision.</p>	
Yes	<p>Employee personnel manuals or handbooks serve as a valuable tool to convey a municipality's policies, procedures and benefits. Many insurance carriers encourage the adoption of such a document and offer discounted rates for their use. These publications should review employees' rights and obligations in areas ranging from discrimination, safety, violence, and harassment to vacation and sick days, holidays, use of township vehicles, smoking and political activity, among others. <u>Has your municipality adopted or updated an employee personnel manual/handbook by resolution or ordinance within the last five years? If yes, please provide in the Comments section the date of the meeting at which the personnel manual was adopted or updated.</u></p>	By Resolution May 28, 2015

Best Practices Worksheet CY 2017/SFY2018

Ocean City City (Cape May)		
0508	<i>Please see Color Key at bottom of sheet for limits on answers</i>	
Answer	Question	Comments
0	Select	
19	Yes	
3	No	
3	N/A	
25	Total Answered:	
22	Score (Yes + N/A)	
88%	Score %	
Chief Administrative Officer's Certification		
	I hereby certify that the information provided in this Best Practices Inventory is accurate to the best of my knowledge.	Certification #(s)
	Name & Title: James V. Mallon, Business Administrator	Date: September 28, 2017
Chief Financial Officer's Certification		
	I hereby certify that the information provided in this Best Practices Inventory is accurate to the best of my knowledge.	Certification #(s): N-0651
	Name: Frank Donato III, CFO	Date: September 28, 2017
Municipal Clerk's Certification		
	I hereby certify that the Governing Body of the Borough of West Cape May in the County of Cape May discussed/will discuss the CY 2017/SFY 2018 Best Practice Inventory as completed herein at a public meeting on August 23, 2017, with the Inventory results, and the certification thereof by the Chief Administrative and Chief Financial Officers, respectively, to be stated in the minutes of said public meeting.	Certification #(s): C-1660
	Name: Melissa G. Bovera, RMC	Date: September 28, 2017

Best Practices Worksheet CY 2017/SFY2018

Ocean City City (Cape May)		
0508	<i>Please see Color Key at bottom of sheet for limits on answers</i>	
Answer	Question	Comments
	Red = "Yes; "No"; "N/A answers permitted	
	Green = Only "Yes" and "No" answers permitted	
Question	Table of Weblinks	
12	http://www.nj.gov/dca/divisions/dlgs/lfns/13/2013-3.pdf	
14	http://www.nj.gov/dca/divisions/dlgs/lfns/16/2016-12.pdf	
16	http://www.nj.gov/dca/divisions/dlgs/lfns/16/2016_20.pdf	
19	http://www.nj.gov/dca/divisions/dlgs/lfns/10/2010-12.doc	
19	http://www.nj.gov/dca/divisions/dlgs/lfns/16/2016-10.pdf	
Score	Aid Withheld	
21-25	No Penalty	
16-20	25% of final CMPTRA and ETR payment withheld	
11-15	50% of final CMPTRA and ETR payment withheld	
6-10	75% of final CMPTRA and ETR payment withheld	
0-5	100% of final CMPTRA and ETR payment withheld	

CITY OF OCEAN CITY
CAPE MAY COUNTY, NEW JERSEY

RESOLUTION

#10

**AMENDING THE 2017
BUDGET OF THE CITY OF OCEAN CITY TO INCLUDE
ADDITIONAL REVENUE FROM THE STATE OF NEW JERSEY, DEPARTMENT OF
TRANSPORTATION, DREDGE MATERIAL MANAGEMENT GRANT**

WHEREAS, N.J.S.A. 40a: 4-87 provides that the Director of the Division of Local Government Services may approve the insertion of any special item of revenue in the budget of any municipality when such item shall have been made available by law and the amount thereof was not determined at the time of the adoption of the budget; and

WHEREAS, said director may also approve the insertion of an item of appropriation for equal amount; and

WHEREAS, the City of Ocean City has received notification of a grant in the amount of \$1,219,935.03 from the State of New Jersey, Department of Environmental Protection, Clean Communities Grant Program and wishes to amend its 2017 Budget to include this amount as a revenue; and

WHEREAS, the Local share of the above referenced grant is zero; and

NOW, THEREFORE, BE IT RESOLVED that the City of Ocean City hereby requests the Director of the Division of Local Government Services to approve the insertion of an item of revenue in the budget of the year 2017 in the sum of \$1,219,935.03 which item is now available as a revenue from:

GENERAL REVENUES

Miscellaneous Revenue-Section F
Special Items of General Revenue Anticipated with
Prior Written Consent of the Director of Local
Government Services:

Public and Private Revenue Offset with Appropriations (continued):
State of New Jersey, Department of Transportation, Dredge Material Management Grant...\$1,219,935.03
pursuant to the provisions of Statute; and

BE IT FURTHER RESOLVED that a like sum of \$1,219,935.03 be and the same is hereby appropriated under the caption of:

- 8. GENERAL APPROPRIATIONS
(A) Operations-Excluded from "CAPS"
Public and Private Programs Offset by Revenues

State of New Jersey, Department of Transportation, Dredge Material Management Grant...\$1,219,935.03

BE IT FURTHER RESOLVED that a copy of this resolution be certified and submitted electronically to the Director of Local Government Services for approval; and

BE IT FINALLY RESOLVED that this amendment be published in the Sentinel Ledger in the issue of September 27, 2017.

Peter V. Madden,
Council President

FILES/Chapter NJDOT Dredging Material Management Grant 2017
Offered by Seconded by

The above resolution was duly adopted by the City Council of the City of Ocean City, New Jersey, at a meeting of said Council duly held on the day of 2017.

NAME	AYE	NAY	ABSENT	ABSTAINED	City Clerk
Barr	_____	_____	_____	_____	
Bergman	_____	_____	_____	_____	
DeVlieger	_____	_____	_____	_____	
Hartzell	_____	_____	_____	_____	
Madden	_____	_____	_____	_____	
McClellan	_____	_____	_____	_____	
Wilson	_____	_____	_____	_____	

CITY OF OCEAN CITY
CAPE MAY COUNTY, NEW JERSEY
RESOLUTION

#11

**AUTHORIZING THE EXECUTION OF A SHARED SERVICES AGREEMENT WITH
THE STATE OF NEW JERSEY, DEPARTMENT OF TRANSPORTATION
REGARDING THE DREDGING OF CARNIVAL BAYOU**

WHEREAS, the City of Ocean City (“Ocean City”) has developed a comprehensive long-range plan for the dredging of adjacent waterways in the back bay and management of dredge materials; and,

WHEREAS, as set forth in *N.J.S.A. 27:1A-78*, the New Jersey Department of Transportation Office of Maritime Resources (“NJDOT”) shall serve as the lead on all maritime matters including but not limited to, dredging, dredging technologies and dredging related issues, as well as State and federal marine transportation systems; and,

WHEREAS, as set forth in *N.J.S.A. 27:1A-80*, the NJDOT shall engage in waterborne, dredging, and related infrastructure development projects which enhance the economic, environmental, and efficient nature of maritime and marine trades services; and,

WHEREAS, as set forth in *N.J.S.A. 27:1A-82*, the NJDOT, in consultation with the New Jersey Department of Environmental Protection and New Jersey Department of Treasury, is authorized to operate lease, or license a dredging facility, or contract for the design, construction, use, management or operation of any State dredging processing facility in such a manner as to produce revenue in support of the maritime industry; and,

WHEREAS, Ocean City is the owner of a dredged material confined disposal facility (CDF) called Route 52 CDF located under the Route 52 bridge and shown on the official municipal Tax Map as being located in Block 850.01, Lot 6 and CDF 83, shown on the official municipal Tax Map as being located in Block 3350.01, Lot 17, both in the City of Ocean City (collectively, the “Property”); and,

WHEREAS, Ocean City is undertaking its 2017 Dredging Project; and,

WHEREAS, certain State-maintained channels located within Ocean City known as #181 USCG Lagoon, #182 USCG Lagoon Spur, #183 Krause’s Cut, #184 Carnival Bayou, #185 Venetian Bayou, and #186 Ocean City require dredging; and,

WHEREAS, Ocean City has agreed to dredge State Channels as a part of their 2017 dredging program, and to thereafter deposit the dredged material into the Property or other suitable permitted location approved by NJDOT; and,

WHEREAS, Ocean City has agreed to dredge #184 Carnival Bayou as a part of their 2017 dredging program; and

WHEREAS, the NJDOT has agreed to compensate Ocean City for the dredging of State Channels, subject to available funding; and,

WHEREAS, the Uniform Shared Services and Consolidation Act, *N.J.S.A. 40A:65-1, et seq.* permits agreements for joint services between municipalities and State agencies; and,

WHEREAS, the City of Ocean City and the NJDOT desire to enter into an agreement for joint services so as to accomplish the dredging described herein in accordance with a written agreement between the two municipalities, a copy of which is on file at the office of the Clerk of Ocean City;

CITY OF OCEAN CITY
CAPE MAY COUNTY, NEW JERSEY

RESOLUTION

NOW, THEREFORE, BE IT RESOLVED by the City Council of the City of Ocean City, County of Cape May, New Jersey as follows:

1. The City of Ocean City accepts and approves the Shared Services Agreement to be entered into with NJDOT, a true copy of which and can be reviewed by the public during normal business hours; and
2. The Mayor, Business Administrator and City Clerk are hereby authorized to execute any and all necessary documents in order to implement this Resolution.

The above resolution was duly adopted by the City Council of the City of Ocean City, New Jersey, at a meeting of said Council duly held on the 28th day of September, 2017.

Peter V. Madden
Council President

Offered by Seconded by

The above resolution was duly adopted by the City Council of the City of Ocean City, New Jersey, at a meeting of said Council duly held on the day of 2017.

NAME	AYE	NAY	ABSENT	ABSTAINED
Barr	_____	_____	_____	_____
Bergman	_____	_____	_____	_____
DeVlieger	_____	_____	_____	_____
Hartzell	_____	_____	_____	_____
Madden	_____	_____	_____	_____
McClellan	_____	_____	_____	_____
Wilson	_____	_____	_____	_____

.....
City Clerk

STATE OF NEW JERSEY
DEPARTMENT OF TRANSPORTATION

DREDGE MATERIAL MANAGEMENT AGREEMENT – OCEAN CITY
#184 Carnival Bayou

THIS AGREEMENT, is made this _____ day of _____, 2017, by Ocean City, located in Cape May County and the New Jersey Department of Transportation (“NJDOT or State”);

WHEREAS, as set forth in N.J.S.A.27:1A-78, the NJDOT Office of Maritime Resources shall serve as the lead on all maritime matters including but not limited to, dredging, dredging technologies and dredging related issues, as well as State and federal marine transportation systems; and

WHEREAS, as set forth in N.J.S.A. 27:1A-80, the NJDOT shall engage in waterborne, dredging, and related infrastructure development projects which enhance the economic, environmental, and efficient nature of maritime and marine trades services; and

WHEREAS, as set forth in N.J.S.A. 27:1A-82, the NJDOT, in consultation with the New Jersey Department of Environmental Protection and New Jersey Department of Treasury, is authorized to operate lease, or license a dredging facility, or contract for the design, construction, use, management or operation of any State dredging processing facility in such a manner as to produce revenue in support of the maritime industry; and

WHEREAS, Ocean City has developed a comprehensive long range plan for the dredging and dredged material management; and

WHEREAS, Ocean City is the owner of a dredged material Confined Disposal Facility (“CDF”) located under the Route 52 bridge and shown on the official municipal Tax Map of Ocean City (**Exhibit A**) as Block 850.01, Lot 6 (“**Route 52 CDF**”) and another CDF located in Block 3350.01, Lot 17 (“**CDF Site 83**”), both in the City of Ocean City, and outlined in red on **Exhibit A** (collectively the “**Property**”); and

WHEREAS, the Route 52 CDF and CDF Site 83 are also depicted on a map entitled “Back Bay Dredging – Dredge Prism City of Ocean City, NJ” attached hereto and incorporated herein as **Exhibit B/C** (on Sheets 15 and 14, respectively); and,

WHEREAS, the navigation channels in the back bay adjacent to Ocean City (“**Ocean City Channels**”), are in need of dredging, as depicted in **Exhibit B/C** (Sheets 1 to 15); and,

WHEREAS, Ocean City is undertaking a multiyear dredging project in Cape May County on the Bay; and,

WHEREAS, Ocean City is planning to authorize a portion of its long term dredging project for the 2017-18 fiscal year; (“**2017 Project**”); and

WHEREAS, the State is responsible for maintenance of the channels located within Ocean City known as #181 USCG Lagoon, #182 USCG Lagoon Spur, #183 Krause’s Cut, #184 Carnival Bayou (“**Carnival Bayou**”), #185 Venetian Bayou, and #186 Ocean City Lagoon, which are also depicted on **Exhibit B/C** (specifically on Sheets 2, 5, 6, 7, 10 and 12; collectively “**State Channels**”), and the State Channels also require dredging; and

WHEREAS, Ocean City has agreed to dredge Carnival Bayou as a part of its 2017 Project, and to deposit the dredged material into the Property or another suitable permitted location approved by NJDOT; and

WHEREAS, the residents and businesses of Ocean City will directly and indirectly benefit from the dredging of the Carnival Bayou; and,

WHEREAS, the NJDOT has agreed to assist Ocean City in bearing the costs of dredging the Carnival Bayou, subject to available funding;

NOW THEREFORE, OCEAN CITY and NJDOT intending to be legally bound, agree as follows:

1. PROJECT

- A. Ocean City shall dredge the Carnival Bayou as part of its 2017 Project, as specified in this agreement. Additional State Channels will be considered by amendment to this Agreement in future years.
- B. Ocean City shall place material dredged from the Carnival Bayou in the Route 52 CDF and CDF Site 83.
- C. The volume of material to be removed in the 2017 Project from Carnival Bayou is estimated at **11,150 Cubic Yards** and from the Ocean City Channels at **3,660 Cubic Yards** for a total of **14,180 Cubic Yards**.
- D. Ocean City shall arrange for financing sufficient to complete the 2017 Project, regardless of the NJDOT's payments due under this Agreement.
- E. The NJDOT will provide inspections and oversight of dredging in the Carnival Bayou for FEMA compliance only, or as the NJDOT deems necessary.
- F. Eligible costs for the Carnival Bayou portion of the 2017 Project include: Design, Construction, Permitting Services, Material Testing & Sampling, Material Management, Construction Inspection, and CDF Capacity.
- G. Ocean City engineers have determined the estimated costs for dredging Carnival Bayou based on the bid opening:
 - i. Dredged Material Placement and Capacity (Including: Design, Construction, Permitting, Material Testing, Inspection): \$631,725.88.
 - ii. Dredging (Including: Design, Construction, Permitting, Material Testing and Sampling, Inspection): \$588,209.14.
- H. The estimated distribution of costs for the 2017 Project between the State and Ocean City, based on the low-bid estimate, are attached hereto as **Exhibit D** and entitled "Allocation of Low-Bid Costs – Carnival Bayou."

2. FUNDING AND PAYMENT

- A. The NJDOT will pay for all eligible costs attributable to dredging the Carnival Bayou ("**State Costs**"). These costs are estimated to be \$1,219,935.03 of the \$1,630,124.88 total estimated cost of 2017 Project. This amount is based on the low bid estimate reflected in **Exhibit D**. This amount shall only be revised consistent with the terms of this Agreement.

- B. The State shall not participate in costs that the NJDOT determines to be outside the purposes listed in Paragraph 1(F), above, excessive or otherwise unallowable. Ocean City shall be afforded an opportunity to challenge this determination at an informal hearing.
- C. Payments shall be made as follows:
- i. Ocean City shall award a contract for the 2017 Project, consistent with all State laws, regulations and orders which are applicable to the NJDOT and Ocean City. NJDOT shall review the award and either concur or reject the award, in its sole discretion. The estimate of the State Costs shall be revised consistent with the contract award.
 - ii. The State shall pay 75% of the State Costs at the time NJDOT concurs in Ocean City's award of the contract. Actual costs exceeding 75% of the estimate shall be paid by the State on a reimbursement basis upon submission of a final voucher with supporting information as required by the NJDOT.
 - iii. The final voucher must be submitted to the NJDOT within six (6) months of acceptance by NJDOT of the dredging of the Carnival Bayou. Acceptance will be based on the results of the After Dredge ("AD") survey and as-built data.
 - iv. If Ocean City requests, progress payments may be made on a reimbursement basis periodically, in the State's sole discretion. Ocean City shall request reimbursement from the State by submitting vouchers in a form supplied by the State with supporting information as required by the State. Progress payments shall be in increments of \$50,000 or greater.
- D. Ocean City hereby certifies that all funds shall be spent only on eligible costs attributable to dredging the Carnival Bayou, as described in this Agreement.
- E. In the event that the State determines that it has reimbursed Ocean City in an amount in excess of the funds actually due under this Agreement, Ocean City shall, upon notice from the State, make timely repayments to the State. If Ocean City fails to timely repay such funds, the State is hereby authorized by this Agreement to deduct those funds from any monies due to Ocean City under the terms of any agreement between the State, its Departments and Agencies and Ocean City or to gain reimbursement through any other remedies available at law or equity.
- F. Any change orders or claims presented by the selected contractor to Ocean City on the Carnival Bayou portion of the 2017 Project are subject to NJDOT review and approval.
- G. Ocean City shall provide cost certification in a form specified by the State and maintain financial records relating to all costs for the 2017 Project, as applicable, and comply with State of New Jersey audit requirements specified therein.
- H. Ocean City shall maintain complete documentation of the 2017 Project for a period of three (3) years after receiving final payment from the State.

- I. Ocean City shall maintain and supply all records and materials which the NJDOT may require in order to successfully obtain federal reimbursement for the 2017 Project and/or the Carnival Bayou portion, regardless of whether those records and materials are specified in this agreement.

3. DESIGN AND CONSTRUCTION

- A. In its agreements for professional and non-professional services relating to the 2017 Project, Ocean City shall require the provision of Public Liability, Comprehensive General Liability, Comprehensive Automobile Liability, Workers' Compensation and Employers' Liability and Professional Liability Insurance, and every such policy shall include Ocean City and the State as additional named insureds.
- B. All work shall comply with all appropriate State and Federal Permits, laws, regulations and orders.
- C. Ocean City shall engage a Professional Engineer, registered in the State of New Jersey, for design services on the 2017 Project. In its agreement for professional services, Ocean City shall require the provision of Errors and Omissions, Professional Liability Insurance and/or Professional Malpractice insurance sufficient to protect the professional services provider from any liability arising out of professional obligations performed pursuant to this Agreement. The insurance shall have a minimum liability of \$1,000,000 per occurrence. The NJDOT shall be named an additional insured on this policy.
- D. State Channel design shall conform to 2013 (or newer) baseline surveys provided by the NJDOT's Office of Maritime Resources. Funding provided is for the maintenance of the existing Carnival Bayou only. Centerline and channel limits, both aerial and min/max dredging depth for Carnival Bayou cannot be altered and/or exceeded without the written approval of the NJDOT.
- E. Ocean City shall provide all maps, reports, detailed plans, permits, supplementary specifications and contract documents required by the NJDOT.
- F. To receive final payment Ocean City must provide a pre-dredge and post-dredge survey of the Carnival Bayou that has been signed and sealed by a Professional Surveyor licensed in the State of New Jersey. These surveys are to be used to calculate the pay volumes for the contractor using the end area averaging method. Pre-dredge and post-dredge surveys shall be conducted on transect lines provided by NJDOT. Ocean City will do the survey and calculations. The pre-dredge survey must be done no more than two (2) weeks before any dredging is performed. The post-dredge survey must be done within two (2) weeks of substantial completion of the project as reported by the contractor and before final acceptance is made. In some cases, additional post dredging surveys may be required if the survey reveals that less than 95% by volume of the sediment within the minimum dredging envelope, as specified in project plans, has been removed and that this failure significantly jeopardizes the navigable use of the channel. NJDOT will not reimburse for more than one (1) post dredging survey. Reimbursement will be made for all volume removed from within the maximum

dredging envelope. In no case will reimbursement be made for volume removed outside of the maximum dredging limit as stated in the plans and specifications.

- G. Ocean City will provide construction inspection for all dredging related work outlined within this agreement.

4. TERM AND TERMINATION

- A. This Agreement shall be effective upon execution by both parties and shall be in effect until the 2017 Project is completed.
- B. This Agreement shall be terminable upon mutual consent of the parties in writing.
- C. This Agreement may be terminated for cause if either party fails to perform its obligations or materially breaches any obligation in the agreement and the failure or breach is not corrected within a reasonable time frame upon receiving written notice from the other party. This Agreement may further be terminated or suspended for Ocean City's failure to comply with all the provisions contained in this Agreement.

5. APPLICABLE LAW AND REGULATIONS

- A. The parties shall comply with all applicable Federal, state, county and municipal laws, ordinances and regulations.
- B. Ocean City shall represent to NJDOT through relevant documents and permits that its operation of the CDFs are in compliance with all applicable Federal, state, county and municipal laws, ordinances and regulations within ten (10) days of execution of this Agreement.

6. PUBLIC ADVERTISEMENT

- A. The municipality shall award a construction contract for the 2017 Project within six (6) months of approval of this Agreement by the NJDOT. The NJDOT may cancel the grant agreement if Ocean City does not award the construction contract by the specified time.
- B. Prior to advertising for bids, Ocean City shall notify the NJDOT if it intends to substantially change the scope of the 2017 Project as proposed in this Agreement. No substantial change shall be included in the project unless it has been approved by the NJDOT.
- C. Ocean City must get approval from the NJDOT of the plans, specifications and engineer's estimate before advertisement. The NJDOT will expedite its review and response.
- D. Prior to advertisement, Ocean City shall submit the following to the NJDOT:
 - i. One (1) copy of the contract plans, specifications, engineer's estimate and engineer's design certification.
 - ii. State and Federal Permits shall be provided immediately upon receipt by Ocean City.
 - iii. Other documents as required.

- E. Ocean City shall advertise and award the contract in accordance with the provisions of the Local Public Contracts Law, N.J.S.A. 40A:11-1, et seq.
- F. Ocean City shall comply with all applicable Federal, State and Local laws, rules, ordinances and regulations.
- G. Within thirty (30) calendar days of opening construction bids, unless the NJDOT grants an extension of this time, Ocean City shall submit the following to NJDOT:
 - i. Two (2) copies of the summary of construction bids.
 - ii. A resolution awarding the contract to the lowest responsible bidder submitting a responsive bid, subject to the prompt approval of the NJDOT.

7. INDEMNIFICATION

- A. Ocean City hereby releases and will protect, defend, indemnify, and save NJDOT, the State, the Commissioner of the New Jersey Department of Transportation, its officers, agents, and employees from and against all claims, liabilities, demands, actions at law, equity, judgments, settlements, losses, damages, and expenses of every character whatsoever for injury to or death of any person or persons whomsoever and for damage to or loss or destruction of property of any kind by whomsoever owned, caused by, resulting from, arising out of, or occurring in connection with the 2017 Project, or incidental to or appertaining thereto, and regardless of whether or not such injury or death or such damage to or loss or destruction of property are due to or chargeable to, in whole or in part, any alleged active or passive negligence or participation in the wrong or upon any alleged breach of any statutory duty or obligation by NJDOT.
- B. Ocean City shall cause its contractor(s) to indemnify, defend, and save harmless the NJDOT, the State, the Commissioner of the New Jersey Department of Transportation, its officers, agents, and employees from and against any and all suits, claims, losses, demands, fees, costs of investigation, cost of defense, and damages of whatever kind or nature arising in connection with this Agreement or the contract between Ocean City and its contractor ("the contract"), regardless of the fault of the NJDOT. The obligations of this paragraph shall survive the expiration, rescission and termination of this Agreement. Ocean City's contractors must agree to provide a defense upon demand by the NJDOT, regardless of the merits of the claim, whether the claim has been filed in court, and if it has been filed, regardless of the stage of those proceedings. The purchase of insurance required by the Agreement or in the contract shall not relieve the contractor of its obligation to provide a defense for the NJDOT.
- C. Ocean City agrees that it shall purchase, and maintain a Comprehensive General Liability policy of insurance and cause its subcontractors to do same. The policy shall name the NJDOT, the Commissioner of Transportation, the State, its officials and employees as an additional insured against liability which arises from the 2017 Project or which arises from any of the claims indicated in Paragraph 7A-B above. The coverage limits shall be a minimum of liability in the amount of \$1,000,000 per occurrence as a combined single limit for bodily injury and property damage.

- D. Ocean City agrees that it shall purchase, and maintain a Marine Liability Insurance policy with a minimum limit of liability that shall be not less than \$2,000,000 per person and \$2,000,000 per occurrence for bodily injury and property damage. Coverage provided under this liability policy shall be on an occurrence basis and shall include, but not be limited to:
- i. Personal injury
 - ii. Contractual liability
 - iii. Premises and operations
 - iv. Products and completed operations
 - v. Independent contractor
 - vi. Waiver of Subrogation for all claims and suits, including recovery of any applicable deductibles
 - vii. Severability of Interest/Separation of Insureds
 - viii. Automotive liability
- E. Ocean City agrees that it shall purchase, and maintain Worker's Compensation applicable to the laws of the State of New Jersey and include an all-states endorsement to extend coverage to any state that may be interpreted to have legal jurisdiction, and Employers Liability Insurance and cause its subcontractors to do same. The policy shall name the NJDOT, the Commissioner of Transportation, the State, its officials and employees as an additional insured. The coverage limits of the policy shall be not less than \$100,000 each accident, \$100,000 disease each employee, and \$500,000 disease aggregate limit. The policy should further be endorsed to include US Longshore and Harbor Workers coverage and Jones Act coverage.
- F. Ocean City shall furnish to the NJDOT a certificate of insurance prior to starting construction together with the declaration pages, showing that Ocean City or its contractors has complied with paragraph 7A - 7E above. All of the certificates shall contain a provision or endorsement that the coverage afforded is not to be canceled, materially changed or renewal refused under this Agreement without NJDOT's prior written approval of such cancellation or change. All certificates, declaration pages and or notices shall be mailed to the New Jersey Department of Transportation as described in Section 20 "Notices."

Insurance coverage in the minimum amounts set forth herein shall not be construed to relieve Ocean City for liability in excess of such coverage, nor does it preclude the NJDOT from taking such other actions as are available to it under any other provisions of this Agreement or otherwise in law.

8. THIRD-PARTY BENEFICIARIES

This Agreement shall not create in any individual or entity the status of a third-party beneficiary and nothing in the Agreement shall be construed to create such status. The rights, duties and obligations contained herein shall operate only between the parties and shall inure solely to the benefit of the parties. The provisions of this Agreement are

intended only to assist the parties in determining and performing the obligations set forth herein and the parties expressly agree that only they shall have any legal or equitable right to seek enforcement of this Agreement, seek any remedy arising out of performance or failure to perform by one of the parties, or bring any action for breach of the Agreement.

9. ASSIGNMENT

This Agreement shall not be assigned without written consent of the NJDOT.

10. DISPUTE

If there are any disputes among the parties concerning this Agreement, the heads or their authorized representatives of each party shall confer to resolve the dispute. All claims made in relation to this Agreement are subject to the provisions of Title 59 of the New Jersey Statutes.

11. AMENDMENT

This Agreement may be amended, supplemented, changed, modified, or altered only by mutual agreement of the parties in writing that shall be effective as of the date stipulated therein.

12. SEVERABILITY/WAIVER

All agreements and covenants contained herein are severable, and in the event any of them shall be held to be invalid by any competent court, this Agreement shall be interpreted as if such invalid agreements or covenants were not contained herein. Should one or more covenants or conditions be waived by either party, such waiver shall not be deemed to waive or render unnecessary the consent or approval of the waiving party to or of any subsequent similar act by the other party.

13. CHOICE OF LAW

This Agreement is being executed and is intended to be performed in the State of New Jersey and shall be governed in all respects by the laws of the State of New Jersey.

14. ENTIRE AGREEMENT

This Agreement contains all the terms and conditions agreed upon by the parties and supersedes all other negotiations, representations, and understandings of the parties, oral or otherwise, regarding the subject matter of this Agreement.

15. BINDING EFFECT

All of the terms, conditions, and covenants to be observed and performed by the parties shall be applicable to and binding upon their several successors and assigns.

16. POLICE POWER

All obligations and penalties are imposed pursuant to the police powers of the State of New Jersey for the enforcement of the law and the protection of public health, safety, welfare and the environment.

17. RESERVATION OF RIGHTS

NJDOT reserves all statutory and common law rights to require Ocean City to take additional action(s) if NJDOT determines that such actions are necessary to protect public

health, safety, welfare and the environment. Nothing in this Agreement shall constitute a waiver of any statutory or common law right of NJDOT to require such additional measures should NJDOT determine that such measures are necessary.

18. SUBJECT TO FUND AVAILABILITY

A failure by the NJDOT to make any payment under this Agreement or to observe and perform any condition on its part to be performed under this Agreement as a result of the failure of the Legislature to appropriate shall not in any manner constitute a breach or default by the NJDOT and the NJDOT shall not be held liable in any manner whatsoever because of the absence of available funding.

19. AUTHORITY

By the signatures below, the parties execute this Agreement and confirm that they are mutually bound by and fully authorized and empowered to enter into and bind their organization by all provisions contained herein.

20. NOTICES

Every notice, approval, consent, or other communication desired or required under this permit should be effective only if the same shall be in writing and sent postage prepaid by overnight mail or United States Registered or certified mail (or a similar mail service available at the time), directed to the other party at its address as follows (or such other address as either party may designate by notice given from time to time in accordance with this section:

If to NJDOT:

Genevieve Clifton
New Jersey Department of Transportation
Office of Maritime Resources
1035 Parkway Avenue
PO Box 600
Trenton, New Jersey 08625-0600

T.: (609) 530-4770

If to Ocean City:

James V. Mallon
City of Ocean City
861 Asbury Avenue
Ocean City, NJ 08226

T.: (609) 525-9357

(REMAINDER OF PAGE INTENTIONALLY LEFT BLANK)

IN WITNESS WHEREOF, the said parties hereto have caused this AGREEMENT to be duly executed and delivered as of the _____ day of the month of _____ in the year of _____, which is the date that this Agreement has been executed and approved by both parties.

ATTEST/WITNESS/AFFIX SEAL:

Melissa G. Bovera, Clerk

By: _____
Jay A. Gillian, Mayor
Dated:

ATTEST/WITNESS/AFFIX SEAL:

STATE OF NEW JERSEY
DEPARTMENT OF TRANSPORTATION

ANIKA JAMES
SECRETARY

By: _____
MICHAEL RUSSO
ACTING ASSISTANT COMMISSIONER

Dated:

Dated:

Approved as to form:

CHRISTOPHER S. PORRINO
ATTORNEY GENERAL OF NEW JERSEY

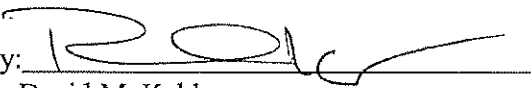
By: 
David M. Kahler
Deputy Attorney General



Date

Exhibit D

Allocation of Low-Bid Costs - Carnival Bayou

Description	QTY	UNIT	UNIT COST	TOTAL COST	NJDOT - 73%	CITY - 27%	TOTAL
MOBILIZATION/DEMOBILIZATION	1	LUMP SUM	\$140,000.00	\$140,000.00	\$102,200.00	\$37,800.00	\$140,000.00
SOIL EROSION AND SEDIMENT CONTROL	1	LUMP SUM	\$6,500.00	\$6,500.00	\$4,745.00	\$1,755.00	\$6,500.00
HYDRAULIC SEDIMENT DREDGING: CARNIVAL BAYOU	14810	C.Y.	\$35.45	\$525,014.50	\$383,260.59	\$141,753.92	\$525,014.50
SITE 83 CDF & WEIR BOX MANAGEMENT	1	LUMP SUM	\$56,000.00	\$56,000.00	\$40,880.00	\$15,120.00	\$56,000.00
DISCHARGE TESTING	1	LUMP SUM	\$5,000.00	\$5,000.00	\$3,650.00	\$1,350.00	\$5,000.00
CDF CAPACITY	14810	C.Y.	\$53.12	\$786,707.20	\$574,296.26	\$212,410.94	\$786,707.20
					\$1,109,031.84	\$410,189.86	\$1,519,221.70
ENGINEERING AND INSPECTION	10%				\$110,903.18		
					\$1,219,935.03		

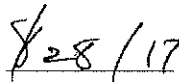
*The Low Bid Total \$1,519,221.70, plus the engineering and inspection costs from the NJDOT portion, \$110,903.18, equals \$1,630,124.88.

REVISIONS		
DATE	BY	LIC. NO.

TAX MAP
 CITY OF OCEAN CITY
 CORDELL COUNTY
 SCALE: 1" = 80'

ARNOLD W. BARNETT
 PROFESSIONAL ENGINEER AND LAND SURVEYOR
 NEW JERSEY LICENSE NO. 11997
 1800 NORTH DUNDY ROAD
 ASBURY PARK, NEW JERSEY 08002
 856-942-9999

NEW JERSEY DEPARTMENT OF TREASURY
 DIVISION OF REVENUE
 APPROVED FOR FILING WITH THE COUNTY CLERK
 OF CORDELL COUNTY, NEW JERSEY
 DATE: 10/15/2006
 BY: [Signature]
 DEPT. 14.001 - REV. 03.03.03

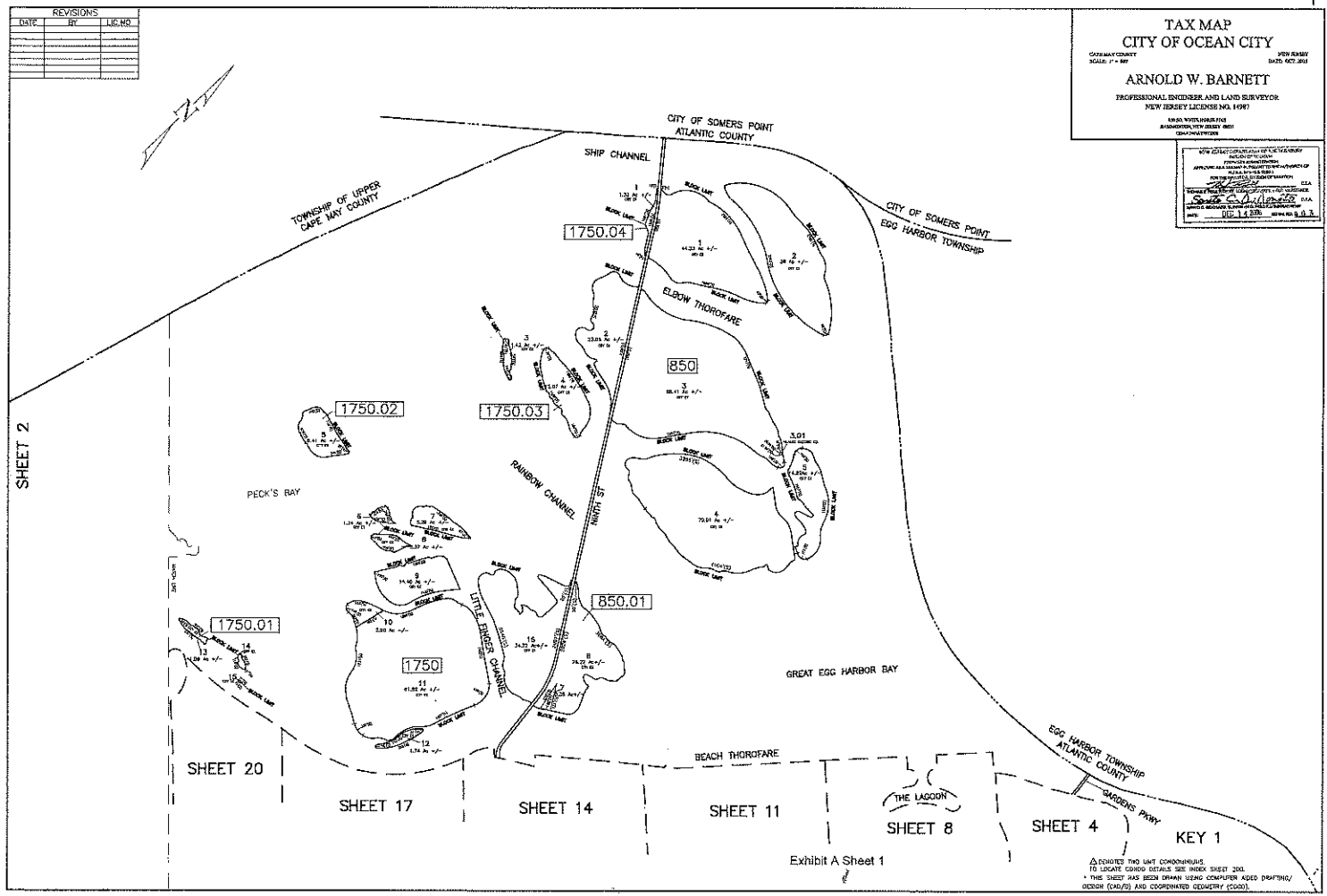

△ SHOWS THE UNIT CONTOURINGS
 TO LOCATE CORRO ESTATES SEE INDEX SHEET 200.
 * THIS SHEET HAS BEEN DRAWN USING COMPUTER AIDED DRAFTING
 (CAD) AND COORDINATED GEOMETRY (GEO).

REVISIONS		
DATE	BY	DESCRIPTION

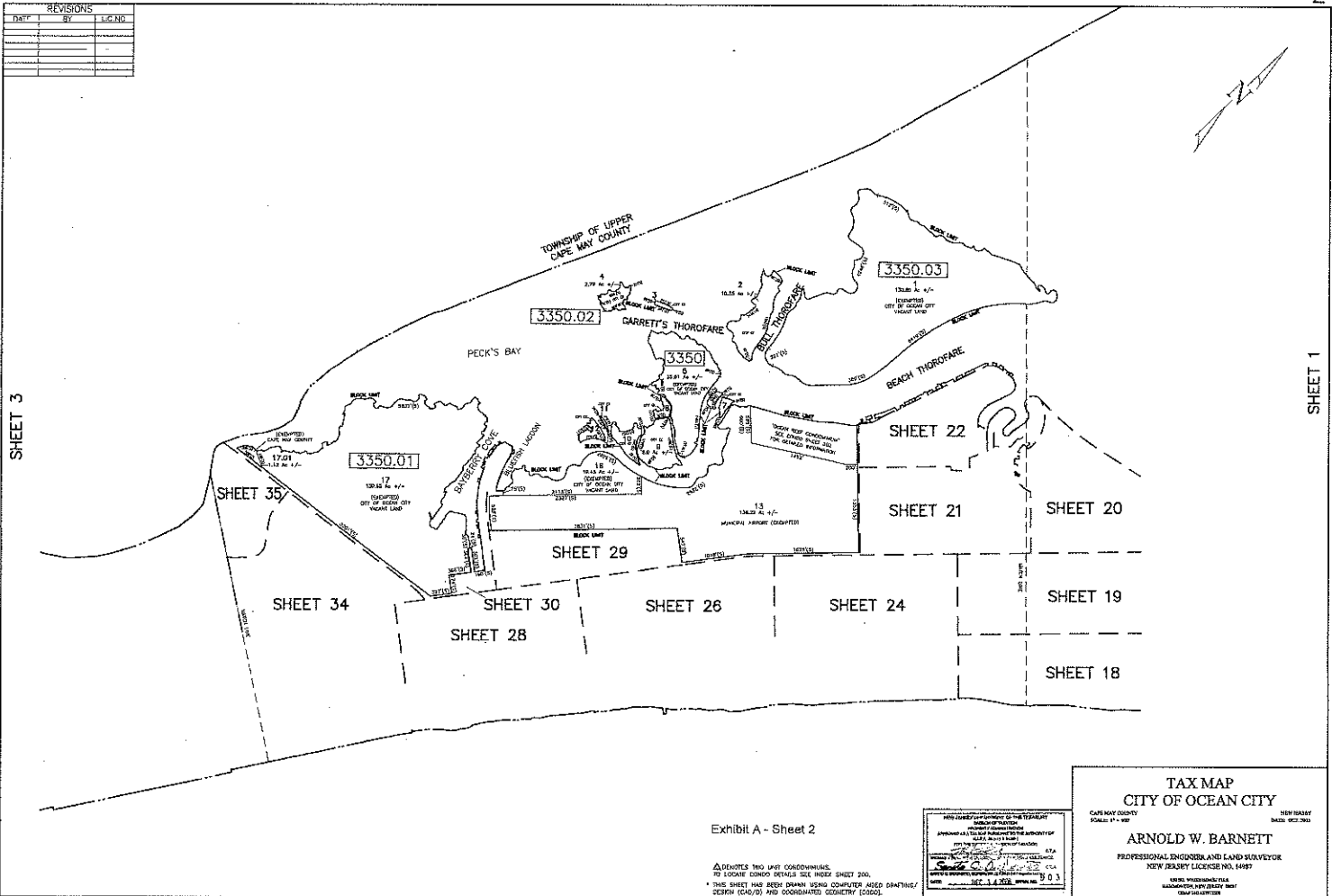
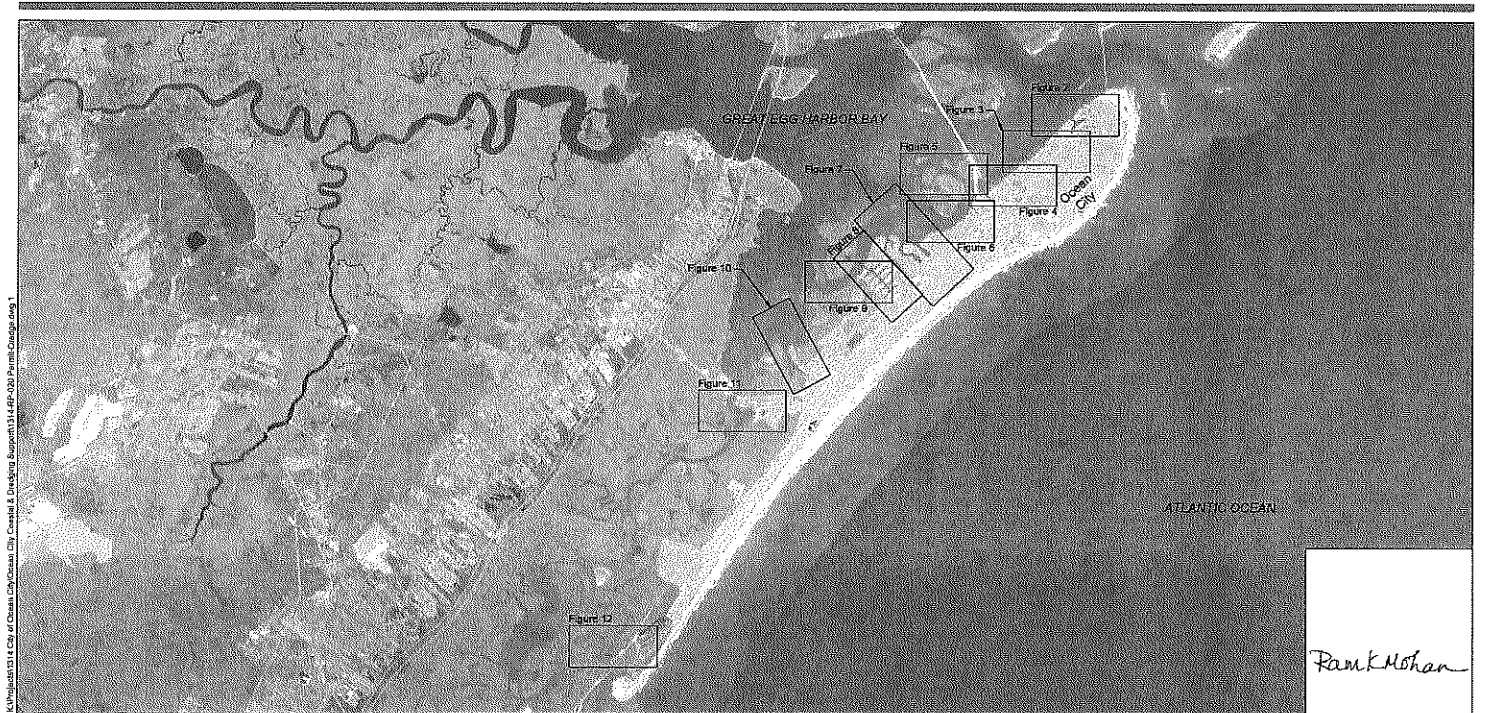

Exhibit A - Sheet 2

△ DENOTES TRAIL UNIT COORDINATES TO LOCATE CONDO DETAILS SEE INDEX SHEET 200.
 * THIS SHEET HAS BEEN DRAWN USING COMPLETED ADDED GRAPHING/DEPTH (CADD) AND COORDINATED (SHEETS) (CADD).

NEW JERSEY DEPARTMENT OF THE TREASURY
 DIVISION OF TAXATION
 APPROVED AS A TRUE AND CORRECT COPY OF THE ORIGINAL BY THE AUTHORITY OF
 STATE TAX COLLECTOR
 JENNIFER M. HANSEN
 STATE TAX COLLECTOR
 STATE OF NEW JERSEY
 DATE: 09/15/2006 10:03 AM
 STATE OF NEW JERSEY
 TAX MAP
 SHEET 18 OF 200

TAX MAP
 CITY OF OCEAN CITY
 SCALE: 1" = 40'
 NEW JERSEY
 DATE: 09/15/2006
 ARNOLD W. BARNETT
 PROFESSIONAL ENGINEER AND LAND SURVEYOR
 NEW JERSEY LICENSE NO. 14497
 1000 WASHINGTON BLVD
 HADDONFIELD, NJ 08033
 (856) 426-0000



Jan 25, 2017 11:08am by: K:\Projects\10314 City of Ocean City\Ocean City Coastal & Dredging Support\10314-00-000 Permit Change.dwg 1

SOURCE: Hydrographic survey conducted by ACT Engineers between September 2015 and January 2016. Aerial imagery from Bing Maps.
 HORIZONTAL DATUM: New Jersey State Plane, NAD83, U.S. Feet.
 VERTICAL DATUM: Mean low water (MLW).

LEGEND:
 Sheet Extent

Exhibit B/C - Sheet 1

Ran K. Mohan

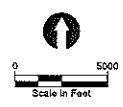
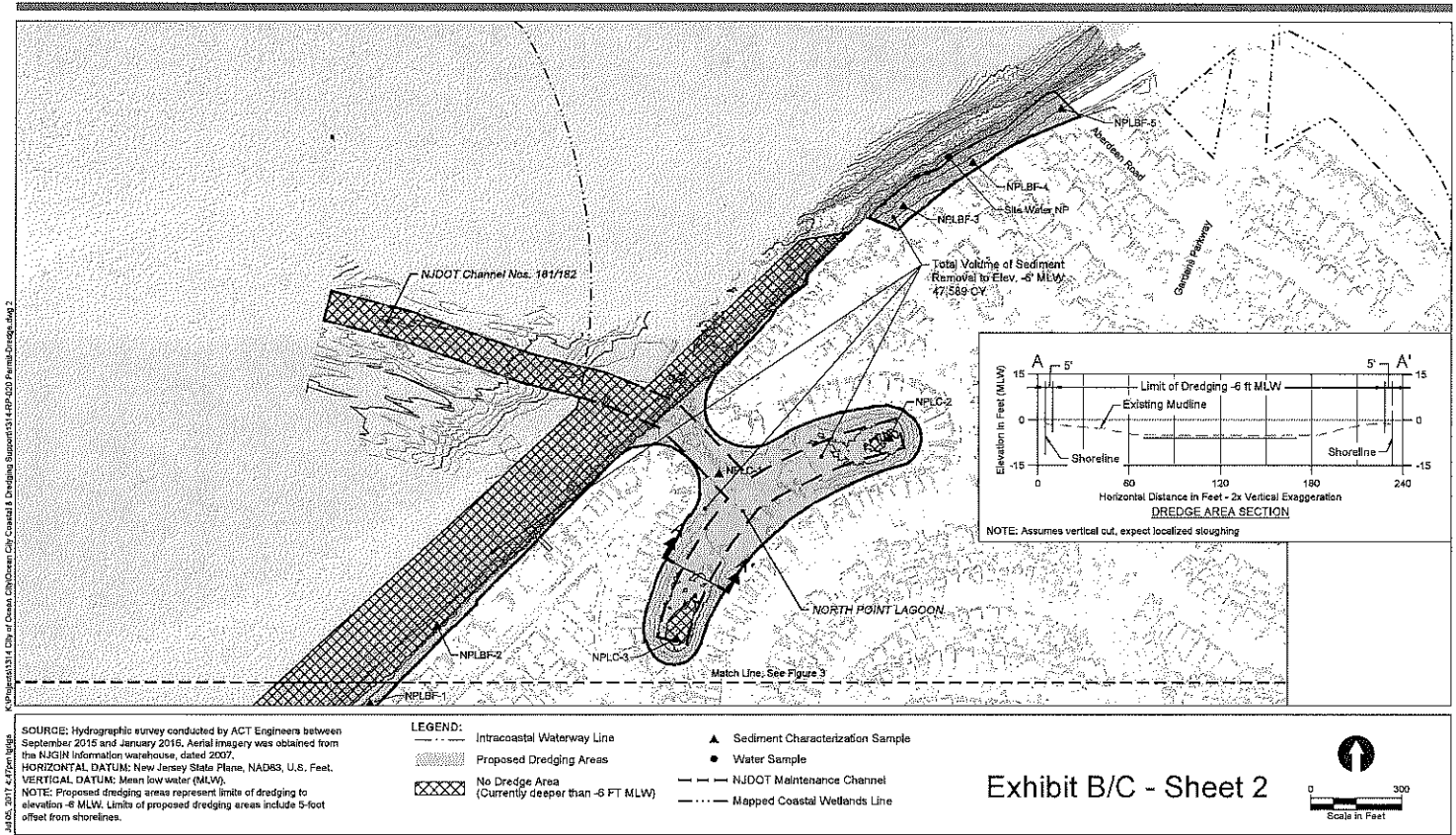

Figure 1
 Vicinity Map and Figure Key
 Back Bay Dredging - Dredge Prism
 City of Ocean City, NJ



SOURCE: Hydrographic survey conducted by ACT Engineers between September 2015 and January 2016. Aerial imagery was obtained from the NJGIN Information warehouse, dated 2007.
 HORIZONTAL DATUM: New Jersey State Plane, NAD83, U.S. Feet.
 VERTICAL DATUM: Mean low water (MLW).
 NOTE: Proposed dredging areas represent limits of dredging to elevation -6 MLW. Limits of proposed dredging areas include 5-foot offset from shorelines.

- LEGEND:**
- Intracoastal Waterway Line
 - ▨ Proposed Dredging Areas
 - No Dredge Area (Currently deeper than -6 FT MLW)
 - ▲ Sediment Characterization Sample
 - Water Sample
 - NJDOT Maintenance Channel
 - Mapped Coastal Wetlands Line

Exhibit B/C - Sheet 2

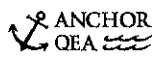
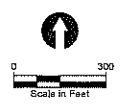
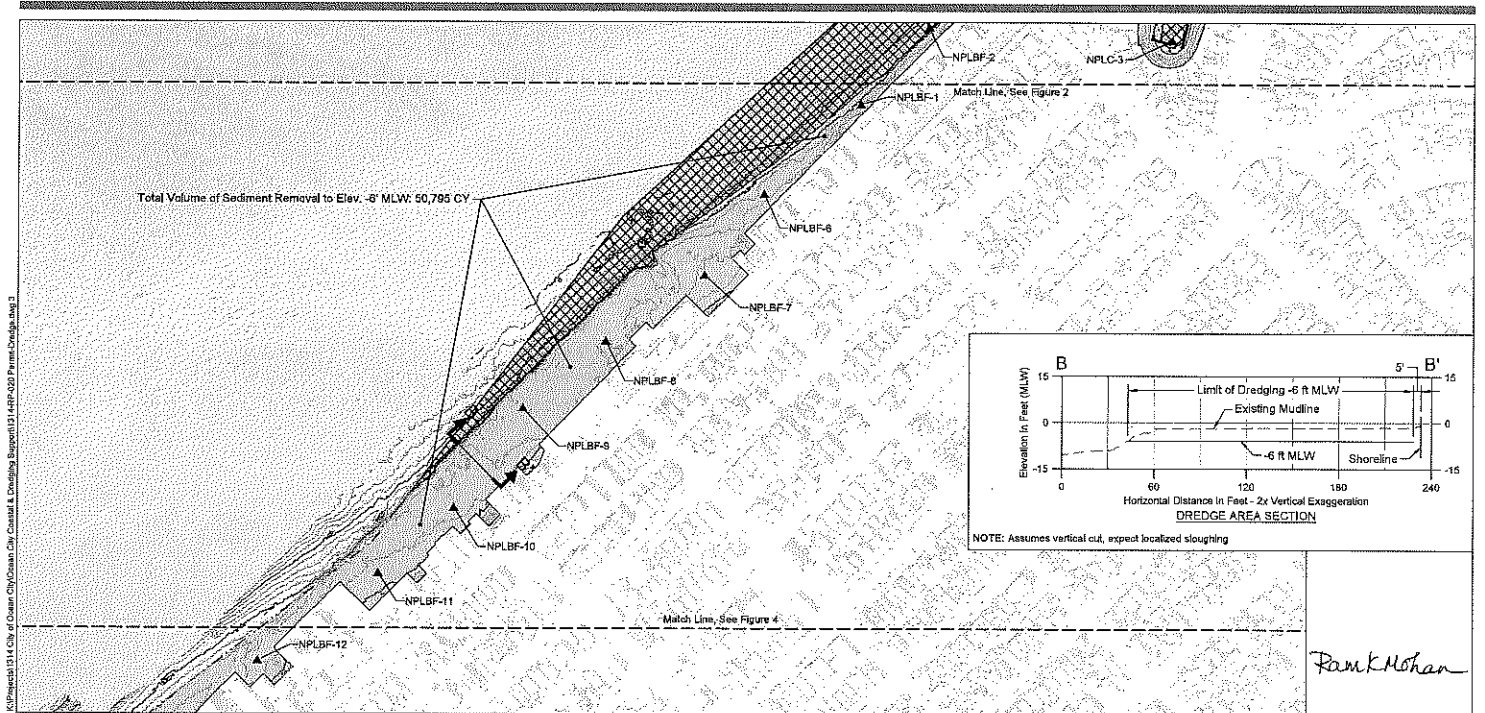

Figure 2
 North Point Lagoon and Various Bayfront
 Back Bay Dredging - Dredge Prism
 City of Ocean City, NJ



SOURCE: Hydrographic survey conducted by ACT Engineers between September 2015 and January 2016. Aerial imagery was obtained from the NJGIN information warehouse, dated 2007.

HORIZONTAL DATUM: New Jersey State Plane, NAD83, U.S. Feet.

VERTICAL DATUM: Mean low water (MLW).

NOTE: Proposed dredging areas represent limits of dredging to elevation -6 MLW. Limits of proposed dredging areas include 5-foot offset from shorelines.

- LEGEND:**
- Intracoastal Waterway Line
 - Proposed Dredging Areas
 - No Dredge Area (Currently deeper than -6 FT MLW)
 - ▲ Sediment Characterization Sample
 - Water Sample
 - NJDOT Maintenance Channel
 - Mapped Coastal Wetlands Line

Exhibit B/C - Sheet 3

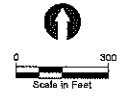
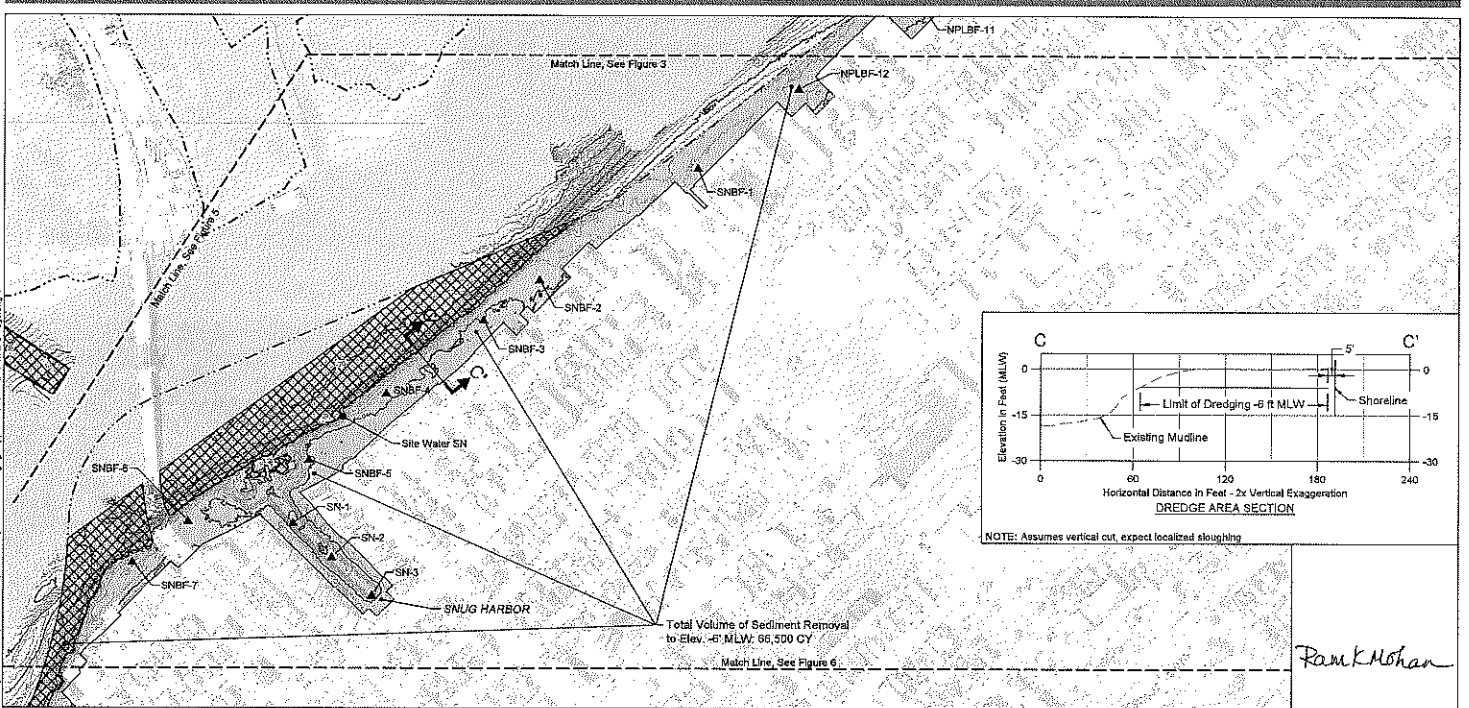

Figure 3
Various Bayfront Between Snug Harbor and North Point Lagoon
Back Bay Dredging - Dredge Prism
City of Ocean City, NJ



SOURCE: Hydrographic survey conducted by ACT Engineers between September 2015 and January 2016. Aerial imagery was obtained from the NJGIN Information warehouse, dated 2007.
 HORIZONTAL DATUM: New Jersey State Plane, NAD83, U.S. Feet.
 VERTICAL DATUM: Mean low water (MLW).
 NOTE: Proposed dredging areas represent limits of dredging to elevation -6 MLW. Limits of proposed dredging areas include 5-foot offset from shorelines.

- LEGEND:**
- Intracoastal Waterway Line
 - Proposed Dredging Areas
 - No Dredge Area (Currently deeper than -6 FT MLW)
 - ▲ Sediment Characterization Sample
 - Water Sample
 - NJDOT Maintenance Channel
 - Mapped Coastal Wetlands Line

Exhibit B/C - Sheet 4

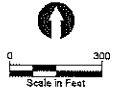
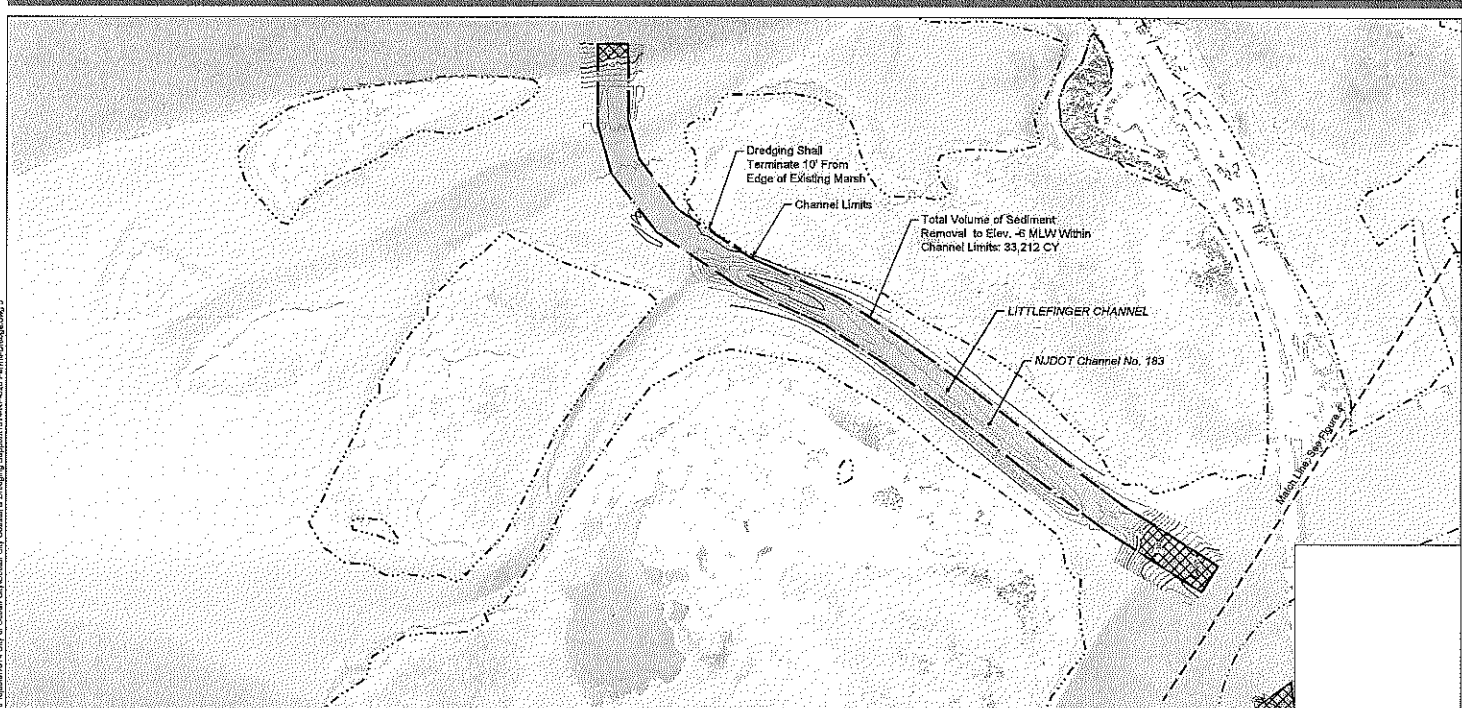

Figure 4
 Snug Harbor and Various Bayfront - 10th Street to 4th Street
 Back Bay Dredging - Dredge Prism
 City of Ocean City, NJ

JUL 05, 2017 4:07 PM btop
 G:\projects\1314_City of Ocean City Coastal & Dredging\Summary\1314-PR-2003_Permit_Dredging.dwg 5



SOURCE: Hydrographic survey conducted by GBA between April 2015 and June 2015 and converted from MLLW to MLW. Aerial imagery was obtained from the NJGIN Information warehouse, dated 2007.
HORIZONTAL DATUM: New Jersey State Plane, NAD83, U.S. Feet.
VERTICAL DATUM: Mean low water (MLW).
NOTE: Proposed dredging areas represent limits of dredging to elevation -6 MLW. Limits of proposed dredging areas include 5-foot offset from shorelines.

- LEGEND:**
- Intracoastal Waterway Line
 - NJDOT Maintenance Channel
 - ▨ Proposed NJDOT Dredging Area
 - Mapped Coastal Wetlands Line
 - ▣ No Dredge Area - Currently deeper than -6 FT MLW
 - ▲ Sediment Characterization Sample

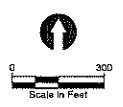

Exhibit B/C - Sheet 5

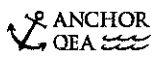
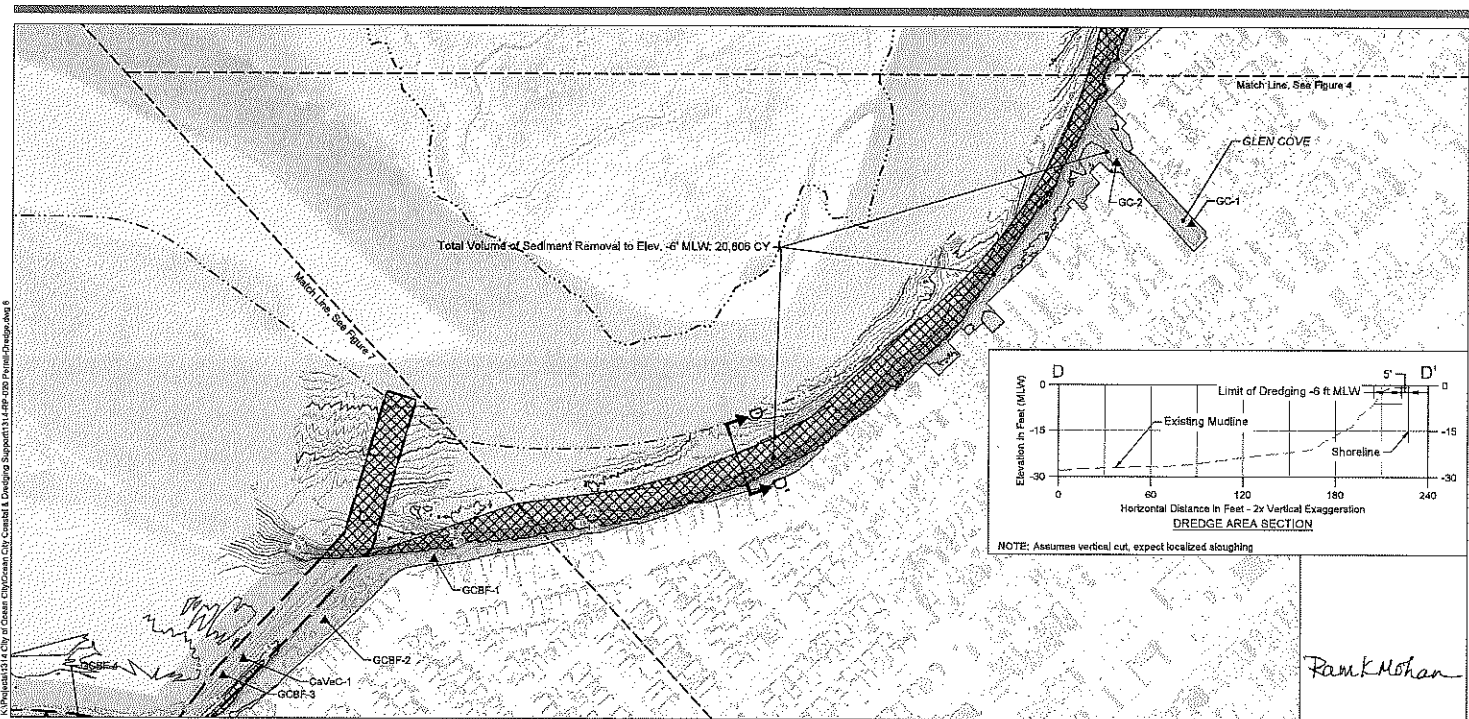

Figure 5
 Krause's Cut NJDOT Maintenance Limits
 Back Bay Dredging - Dredge Prism
 City of Ocean City, NJ



SOURCE: Hydrographic survey conducted by ACT Engineers between September 2015 and January 2016. Aerial imagery was obtained from the NJGIN information warehouse, dated 2007.
 HORIZONTAL DATUM: New Jersey State Plane, NAD83, U.S. Feet.
 VERTICAL DATUM: Mean low water (MLW).
 NOTE: Proposed dredging areas represent limits of dredging to elevation -6' MLW. Limits of proposed dredging areas include 5-foot offset from shorelines.

- LEGEND:**
- Intracoastal Waterway Line
 - Proposed Dredging Areas
 - No Dredge Area (Currently deeper than -6 FT MLW)
 - ▲ Sediment Characterization Sample
 - Water Sample
 - NJDOT Maintenance Channel
 - Mapped Coastal Wetlands Line

Exhibit B/C - Sheet 6

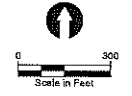
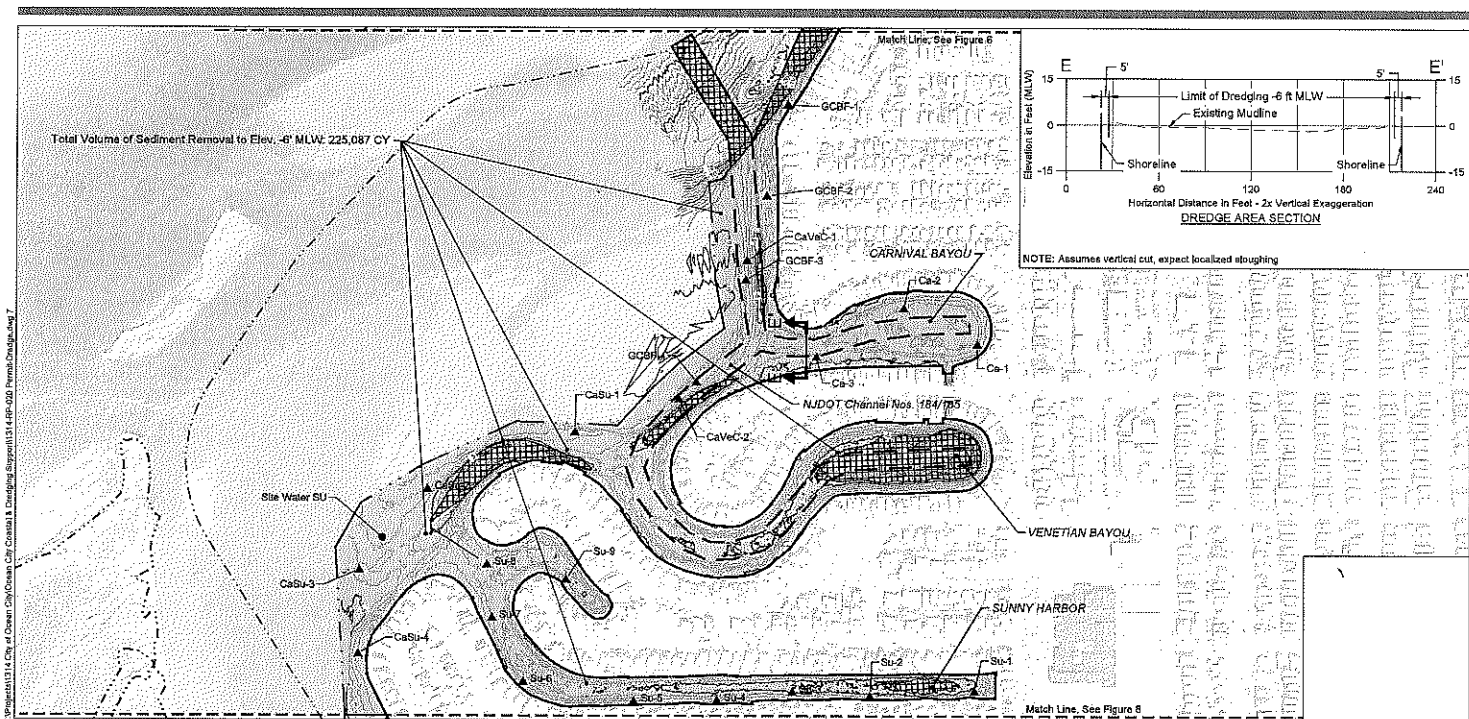

Figure 6
 Glen Cove and Various Bayfront
 Back Bay Dredging - Dredge Prism
 City of Ocean City, NJ



SOURCE: Hydrographic survey conducted by ACT Engineers between September 2015 and January 2016. Aerial imagery was obtained from the NJGIN information warehouse, dated 2007.

HORIZONTAL DATUM: New Jersey State Plane, NAD83, U.S. Feet.

VERTICAL DATUM: Mean low water (MLW).

NOTE: Proposed dredging areas represent limits of dredging to elevation -6' MLW. Limits of proposed dredging areas include 5-foot offset from shorelines.

- LEGEND:**
- - - Intracoastal Waterway Line
 - ▨ Proposed Dredging Areas
 - ▩ No Dredge Area (Currently deeper than -6' FT MLW)
 - ▲ Sediment Characterization Sample
 - Water Sample
 - - - NJDOT Maintenance Channel
 - ⋯ Mapped Coastal Wetlands Line

Exhibit B/C - Sheet 7

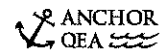
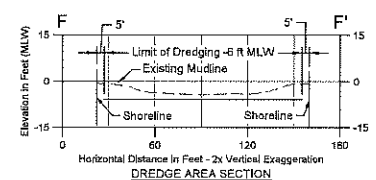
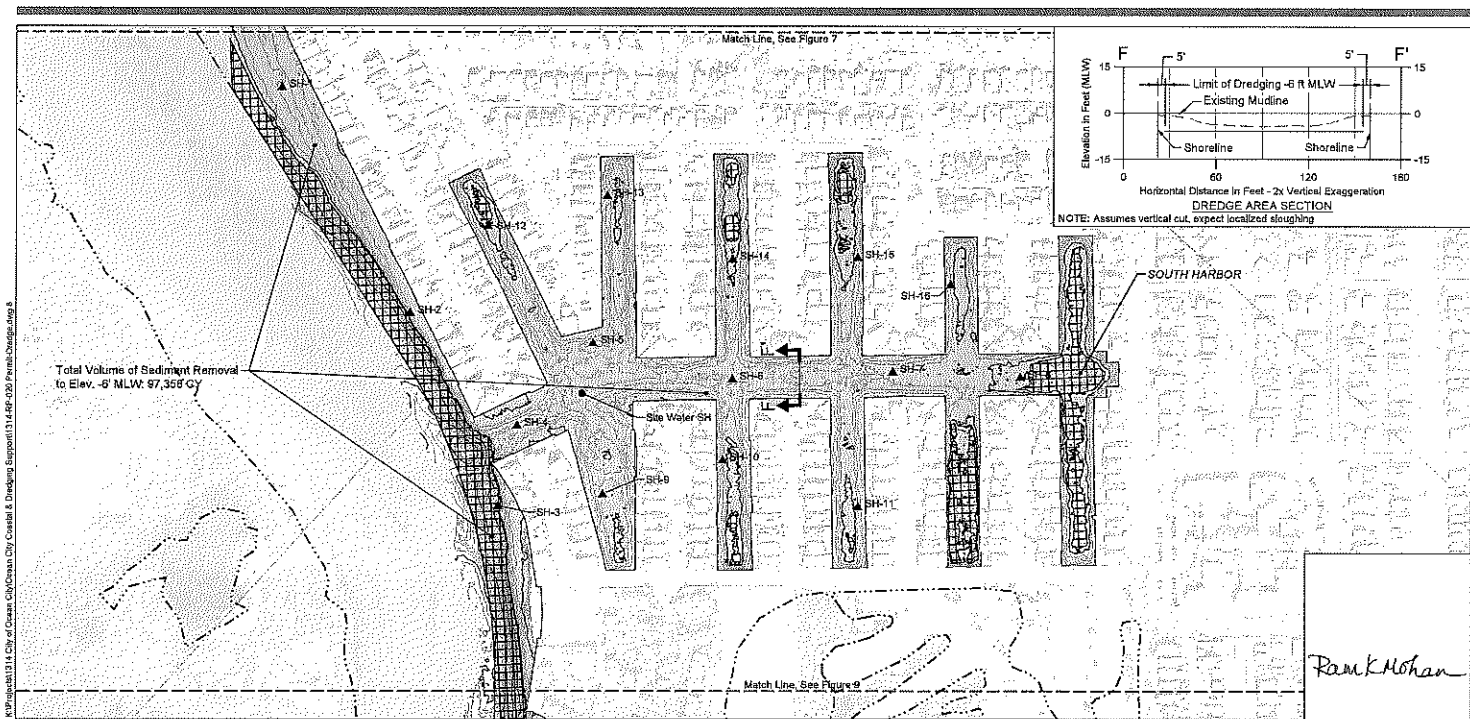

Figure 7
Carnival Bayou, Venetian Bayou, Sunny Harbor, and Various Bayfront Back Bay Dredging - Dredge Prism
City of Ocean City, NJ



SOURCE: Hydrographic survey conducted by ACT Engineers between September 2015 and January 2016. Aerial imagery was obtained from the NJGIN information warehouse, dated 2007.
 HORIZONTAL DATUM: New Jersey State Plane, NAD83, U.S. Feet.
 VERTICAL DATUM: Mean low water (MLW).
 NOTE: Proposed dredging areas represent limits of dredging to elevation -6 MLW. Limits of proposed dredging areas include 5-foot offset from shorelines.

- LEGEND:**
- Intracoastal Waterway Line
 - Proposed Dredging Areas
 - No Dredge Area (Currently deeper than -6 FT MLW)
 - ▲ Sediment Characterization Sample
 - Water Sample
 - NJDOT Maintenance Channel
 - Mapped Coastal Wetlands Line

Rank Mohan



Exhibit B/C - Sheet 8

Figure 8
 South Harbor and Various Bayfront
 Back Bay Dredging - Dredge Prism
 City of Ocean City, NJ

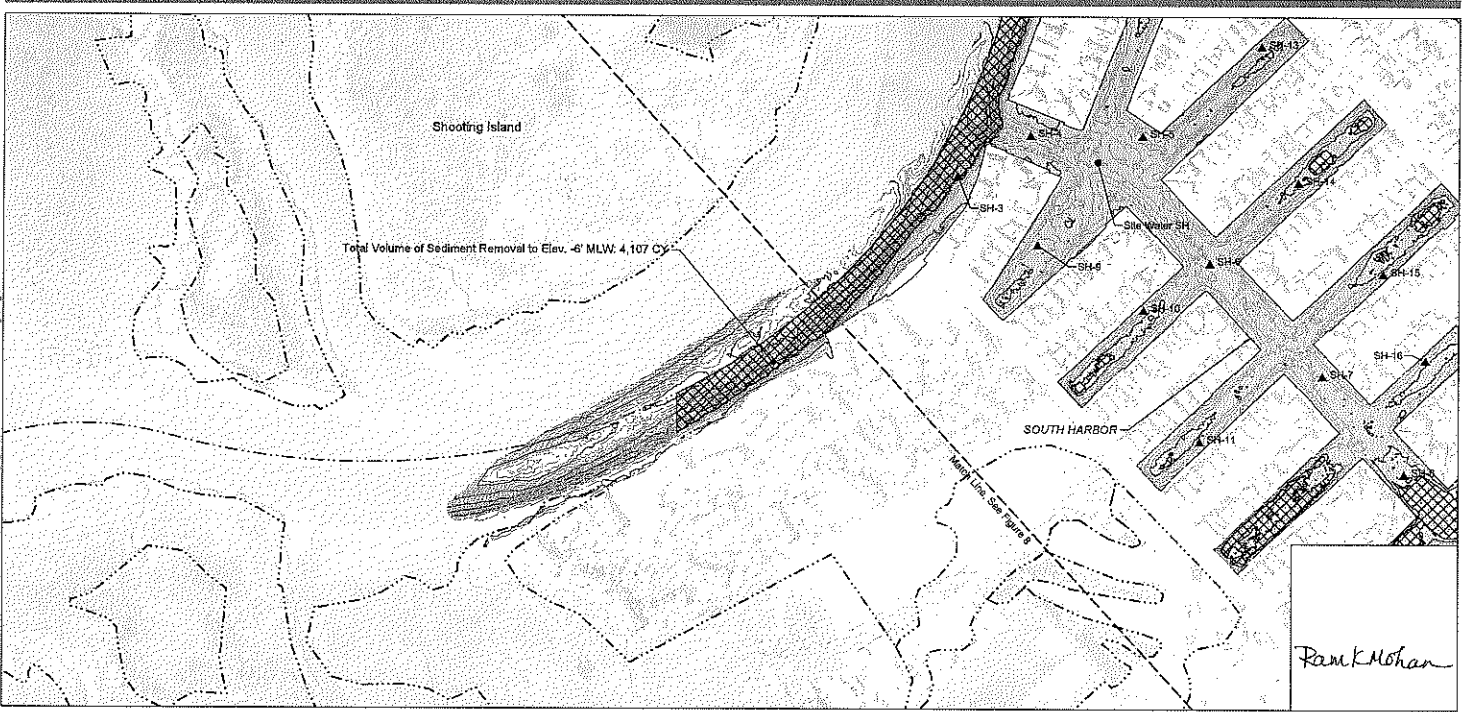

Apr. 22, 2017 11:41 AM
 10/20/2017 11:41 AM
 City of Ocean City, Coastal E. Dredging, Support 11449-000 Permitting, 9

SOURCE: Hydrographic survey conducted by ACT Engineers between September 2015 and January 2016. Aerial Imagery was obtained from the NJGIN Information warehouse, dated 2007.
 HORIZONTAL DATUM: New Jersey State Plane, NAD83, U.S. Feet.
 VERTICAL DATUM: Mean low water (MLW).
 NOTE: Proposed dredging areas represent limits of dredging to elevation -6 MLW. Limits of proposed dredging areas include 5-foot offset from shorelines.

LEGEND:
 - - - - - Intracoastal Waterway Line
 Proposed Dredging Areas
 No Dredge Area (Currently deeper than -6 FT MLW)
 ▲ Sediment Characterization Sample
 ● Water Sample
 - - - - - NJDOT Maintenance Channel
 - - - - - Mapped Coastal Wetlands Line

Exhibit B/C - Sheet 9

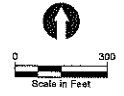
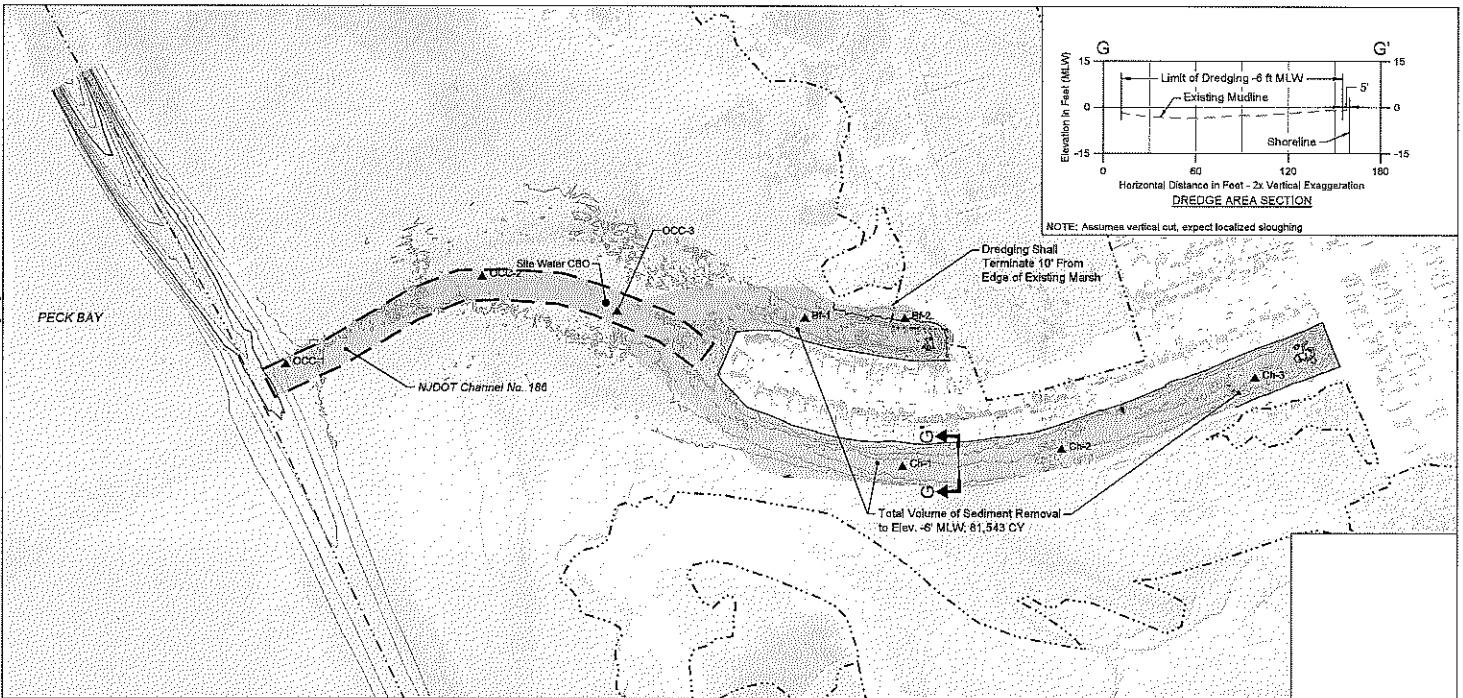

Figure 9
 Various Bayfront Southwest of South Harbor
 Back Bay Dredging - Dredge Prism
 City of Ocean City, NJ

JUL 05, 2017 4:47pm V010
 C:\Users\j314\OneDrive\Documents\Drawings\Bays\1514-PR-030\Prism\Drawg_Aug_10



SOURCE: Hydrographic survey conducted by ACT Engineers between September 2015 and January 2016. Aerial Imagery was obtained from the NJGIN Information warehouse, dated 2007.
 HORIZONTAL DATUM: New Jersey State Plane, NAD83, U.S. Feet.
 VERTICAL DATUM: Mean low water (MLW).
 NOTE: Proposed dredging areas represent limits of dredging to elevation -6 MLW. Limits of proposed dredging areas include 5-foot offset from shorelines.

- LEGEND:**
- Intracoastal Waterway Line
 - Proposed Dredging Areas
 - No Dredge Area (Currently deeper than -6 FT MLW)
 - Sediment Characterization Sample
 - Water Sample
 - NJDOT Maintenance Channel
 - Mapped Coastal Wetlands Line

Exhibit B/C - Sheet 10

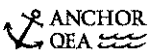
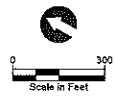
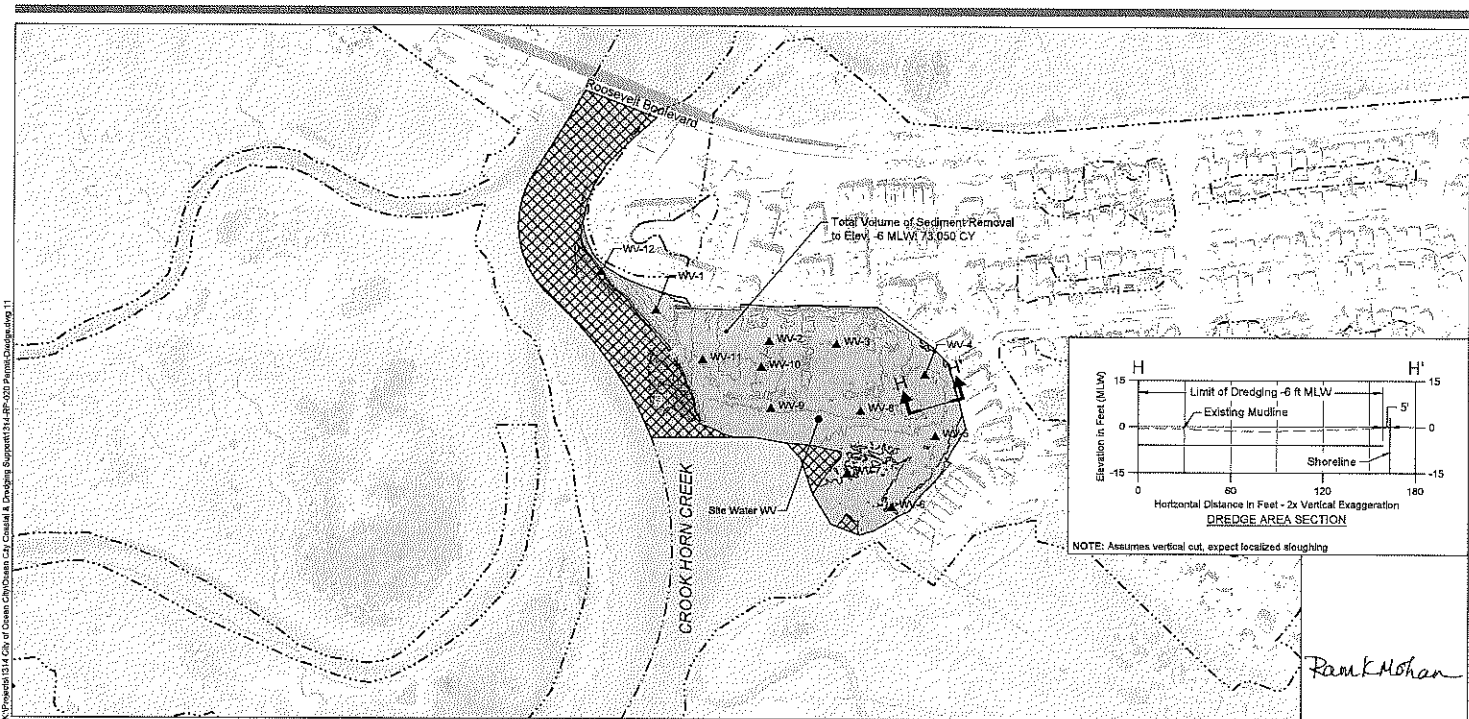

Figure 10
 Clubhouse Lagoon, Bluefish Lagoon, and Ocean City Lagoon
 Back Bay Dredging - Dredge Prism
 City of Ocean City, NJ



SOURCE: Hydrographic survey conducted by ACT Engineers between September 2015 and January 2016. Aerial Imagery was obtained from the NJGIN information warehouse, dated 2007.
 HORIZONTAL DATUM: New Jersey State Plane, NAD83, U.S. Feet.
 VERTICAL DATUM: Mean low water (MLW).
 NOTE: Proposed dredging areas represent limits of dredging to elevation -6 MLW. Limits of proposed dredging areas include 5-foot offset from shorelines.

- LEGEND:**
- Intracoastal Waterway Line
 - Proposed Dredging Areas
 - No Dredge Area (Currently deeper than -6 FT MLW)
 - Sediment Characterization Sample
 - Water Sample
 - NJDOT Maintenance Channel
 - Mapped Coastal Wetlands Line

Exhibit B/C - Sheet 11

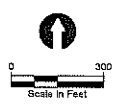
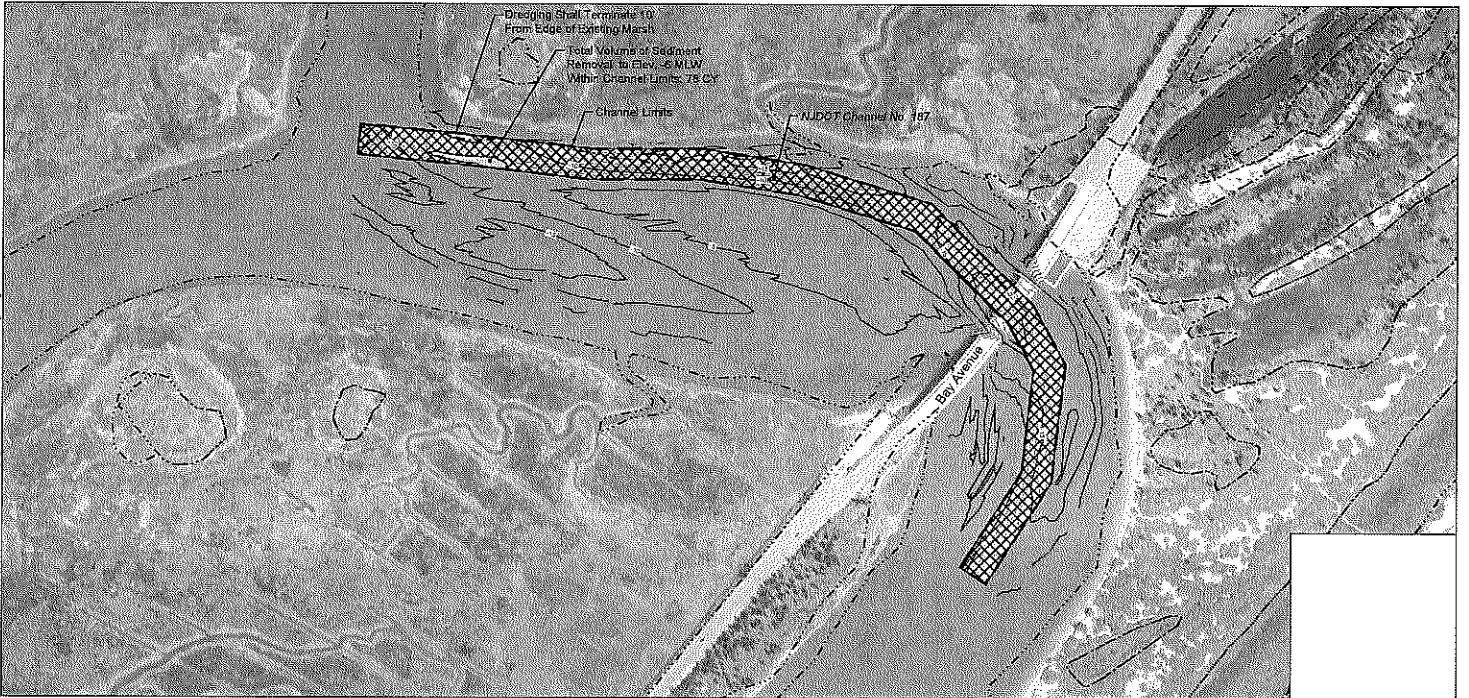

Figure 11
 Waterview
 Back Bay Dredging - Dredge Prism
 City of Ocean City, NJ





AUG. 2017 4:58pm baba
 \p\project\1314_City of Ocean City\Cross-Channel & Dredging\Bibbman1314_1401-0207 Permit_Dredging_Sheet 12

SOURCE: Hydrographic survey conducted by GBA between April 2015 and June 2015 and converted from MLLW to MLW. Aerial Imagery was obtained from the NJGIN Information warehouse, dated 2007.
HORIZONTAL DATUM: New Jersey State Plane, NAD83, U.S. Feet.
VERTICAL DATUM: Mean low water (MLW).
NOTE: Proposed dredging areas represent limits of dredging to elevation -6 MLW. Limits of proposed dredging areas include 5-foot offset from shorelines.

LEGEND:
 - - - - - Intracoastal Waterway Line
 - - - - - NJDOT Maintenance Channel
 [Hatched Box] Proposed NJDOT Dredging Area
 [Cross-hatched Box] No Dredge Area - Currently deeper than -6 FT MLW
 [Dotted Line] Mapped Coastal Wetlands Line
 ▲ Sediment Characterization Sample

Exhibit B/C - Sheet 12

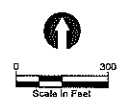
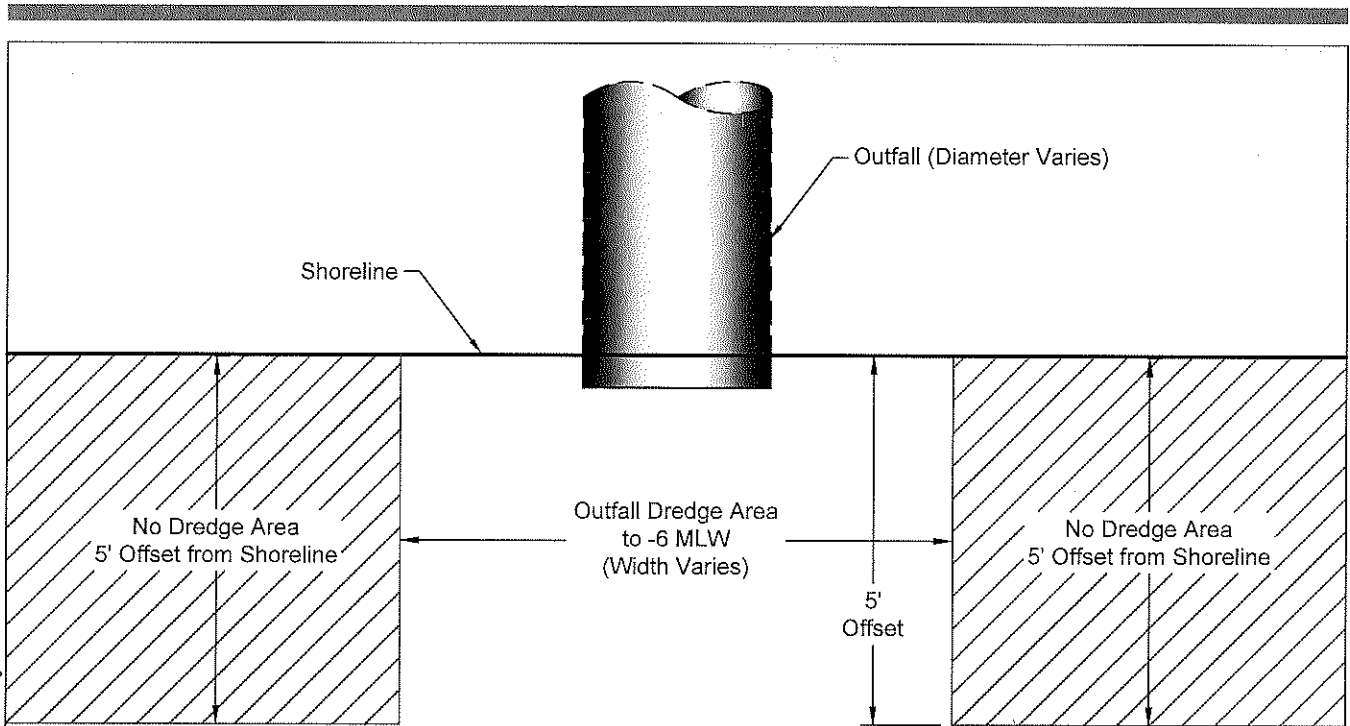
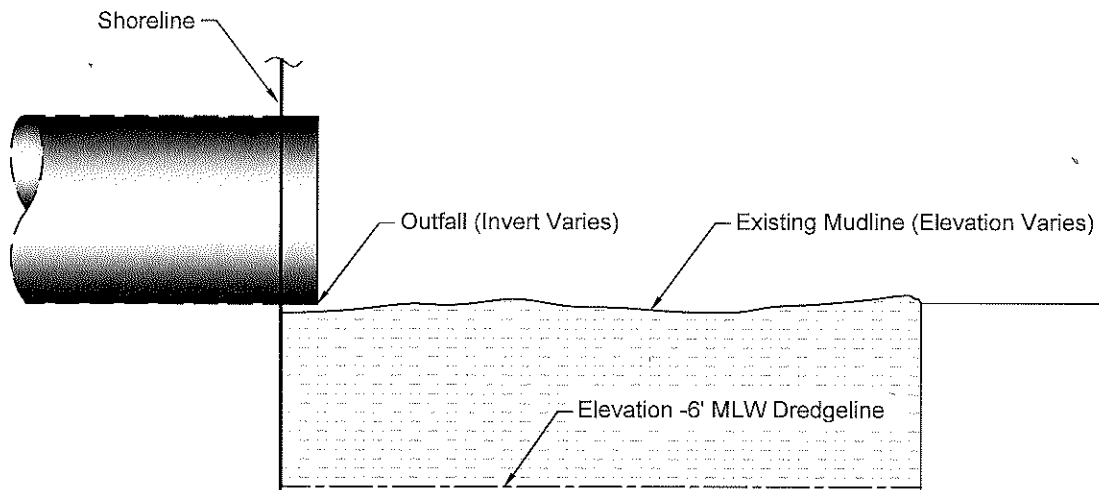

Figure 12
 Corson's Inlet Ramp Channel NJDOT Maintenance Limits
 Back Bay Dredging - Dredge Prism
 City of Ocean City, NJ

K:\Projects\1314 City of Ocean City\Ocean City Coastal & Dredging Support\1314-RP-016 Outfall.dwg 13
Jan 23, 2017 11:38am tgriga



Outfall Dredge Area Plan (Typ.)
NTS



Outfall Dredge Area Section (Typ.)
NTS

Ramk Mohan

NOTE: Assumes vertical cut, expect localized sloughing.

Exhibit B/C - Sheet 13

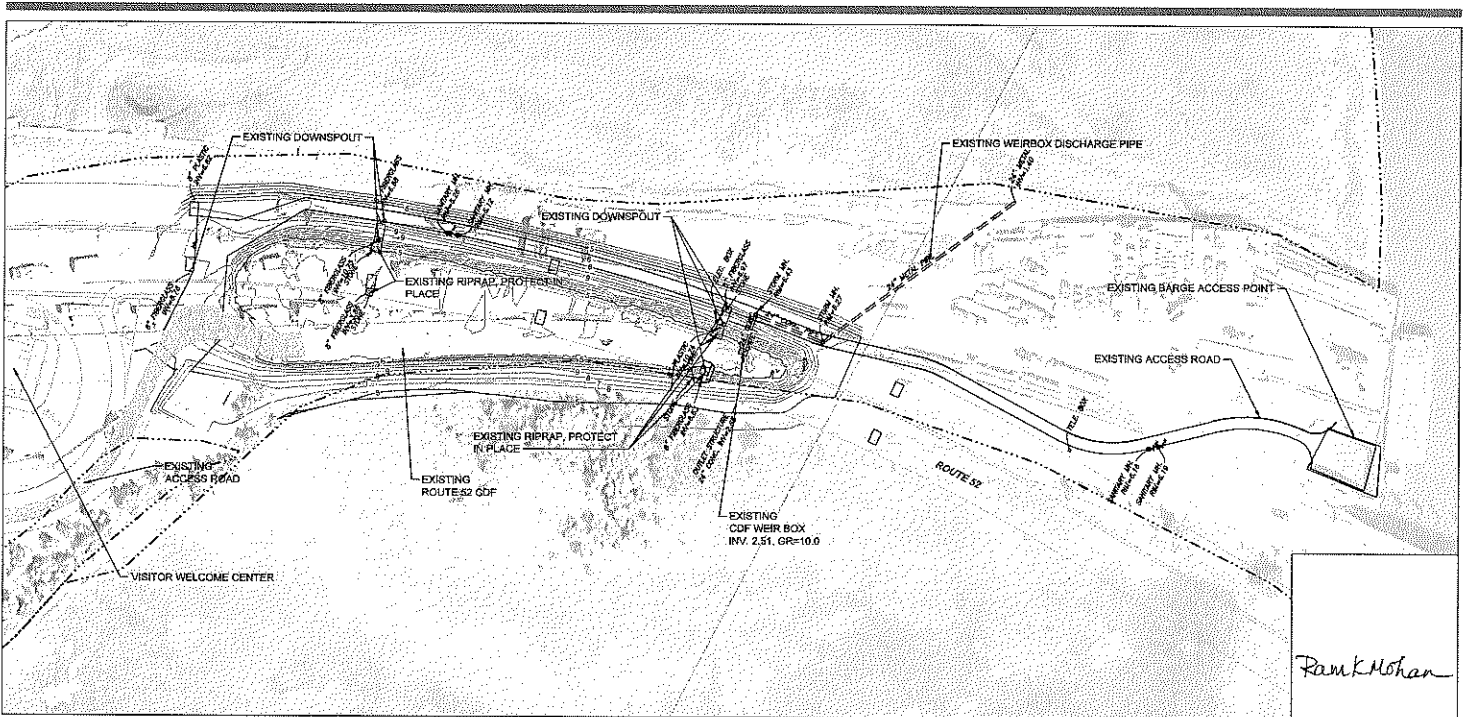

SOURCE: Base maps and site information provided by the city based on design performed by Duffield Associates (2014), and 2016 topographic survey data collected by ACT Engineers.
 HORIZONTAL DATUM: Washington State Plane North, NAD83, U.S. Feet.
 VERTICAL DATUM: Mean Lower Low Water (MLLW).

LEGEND
 — Existing Grade (1' and 5' Interval)
 - - - Mapped Coastal Wetlands Line

Exhibit B/C - Sheet 15



Figure 15
 Route 52 Confined Disposal Facility Site Overview
 Back Bay Dredging
 City of Ocean City, NJ

RESOLUTION

#12

**AUTHORIZING THE EXECUTION OF A CONTRACT FOR SALE OF REAL ESTATE
AND A LEASING AND MANAGEMENT AGREEMENT
WITH THE COUNTY OF CAPE MAY, NEW JERSEY
REGARDING 19 W. 9th SREET (BLOCK 811.01, LOT 3),
OCEAN CITY, CAPE MAY COUNTY, NEW JERSEY**

WHEREAS, the City owns property commonly known as 19 W. 9th Street and shown on the municipal tax map as Block 811.01, Lot 3 in the City of Ocean City (the "Property"); and,

WHEREAS, the City has affirmatively requested that Cape May County (the "County") consider purchasing the Property, pursuant to the County's Open Space and Farmland Preservation Program; and,

WHEREAS, this request was formalized in a document entitled "Open Space Application", dated July 1, 2016 and executed by Jim Mallon, Administrator for the City of Ocean City; and,

WHEREAS, the referenced Application was recommended for approval by the County's Open Space Review Board; and,

WHEREAS, the County and the City have negotiated a mutually agreeable purchase price; and,

WHEREAS, the County's Board of Chosen Freeholders has authorized the acquisition of the referenced property, subject to the consummation of the attached Contract for Sale of Real Estate; and,

WHEREAS, simultaneously with the execution of the Contract for Sale of Real Estate, the City and the County will execute a Leasing and Management Agreement, a copy of which is attached hereto and pursuant to which the City will assume immediate and complete responsibility for the care, management, control, maintenance, insurance and general operation of the property; and,

WHEREAS, the City believes that the execution of these contracts will be of value to the City's taxpayers;

NOW, THEREFORE, BE IT RESOLVED by the City Council of the City of Ocean City, County of Cape May, New Jersey as follows:

1. The City accepts and approves the Contract for Sale of Real Estate and the Leasing and Management Agreement to be entered into with the County, true copies of which are on file at the office of the Clerk of Ocean City and can be reviewed by the public during normal business hours; and
2. The Mayor, Business Administrator and City Clerk are hereby authorized to execute any and all necessary documents in order to implement this Resolution.

The above resolution was duly adopted by the City Council of the City of Ocean City, New Jersey, at a meeting of said Council duly held on the 28th day of September, 2017.

Peter V. Madden
Council President

Offered by Seconded by

The above resolution was duly adopted by the City Council of the City of Ocean City, New Jersey, at a meeting of said Council duly held on the day of 2017.

NAME	AYE	NAY	ABSENT	ABSTAINED
Barr	_____	_____	_____	_____
Bergman	_____	_____	_____	_____
DeVlieger	_____	_____	_____	_____
Hartzell	_____	_____	_____	_____
Madden	_____	_____	_____	_____
McClellan	_____	_____	_____	_____
Wilson	_____	_____	_____	_____

.....
City Clerk

CONTRACT FOR SALE OF REAL ESTATE

This Contract for Sale is made on _____, 2017

BETWEEN **THE CITY OF OCEAN CITY, a municipal corporation of the State of New Jersey,**

whose address is 861 Asbury Avenue
Ocean City, New Jersey 08226

referred to as the "Seller",

AND **THE COUNTY OF CAPE MAY, a public body corporate and politic of the State of New Jersey**

whose address is 4 Moore Road
Cape May Court House, New Jersey 08210

referred to as the "Buyer".

The words "Buyer" and "Seller" include all Buyers and all Sellers listed above.

- 1. Purchase Agreement.** The Seller agrees to sell and the Buyer agrees to buy the Property described in this contract.
- 2. Property.** The property (called the "Property") to be sold consists of: (a) the land and all the buildings, other improvements and fixtures on the land; (b) all of the Seller's rights relating to the land; and (c) all personal property specifically included in this contract. The Real Property to be sold is commonly known as a tract at 19 West Ninth Street, in the City of Ocean City, in the County of Cape May and State of New Jersey. It is shown on the municipal tax map as Block 811.01, Lot 3.
- 3. Purchase Price.** The purchase price is \$475,000.00.
- 4. Payment of Purchase Price.** The Buyer will pay the purchase price as follows:

Previously paid by the Buyer (initial deposit)	\$	0.00
Upon signing of this Contract (balance of deposit)	\$	0.00
Cash at Closing	\$	475,000.00
- 5. Time and Place of Closing.** The closing date cannot be made final at this time. The Buyer and Seller agree to make settlement as soon as possible. Both parties will fully cooperate so the closing can take place on or before the estimated date. The closing will be held at the Cape May County Administration Building, 4 Moore Road, Cape May Court House, New Jersey 08210.
- 6. Transfer of Ownership.** At the closing, the Seller will transfer ownership of the Property to the Buyer. The Seller will give the Buyer a properly executed deed and an adequate affidavit of title. If the Seller is a corporation, it will also deliver a corporate resolution authorizing the sale.
- 7. Type of Deed.** A deed is a written document used to transfer ownership of property. In this sale, the Seller agrees to provide and the Buyer agrees to accept a deed known as bargain and sale with covenants against grantors' acts.
- 8. Physical Condition of the Property.** This Property is being sold "As is." The Seller does not make any claims or promises about the condition or value of any of the Property included in this sale, other than the representations contained herein below in paragraphs 25, 26, 30 and 32. The Buyer has inspected the Property and relies on this inspection and any rights which may be provided for elsewhere in this contract. The Seller agrees to maintain the grounds, buildings and improvements subject to ordinary wear and tear. Seller agrees to leave the Property free of debris.

9. Risk of Loss. The Seller is responsible for any damage to the Property, except for normal wear and tear, until the closing. If there is damage, the Buyer, at its sole option, can proceed with the closing or cancel the contract.

10. Inspection of the Property. The Seller agrees to permit the Buyer to inspect the Property at any reasonable time before the closing. The Seller will permit access for all inspections provided for in this contract.

11. Building and Zoning Laws. The Buyer intends to use the Property as open space. The Seller states that this use does not violate any applicable zoning ordinance building code or other law. The Seller will obtain and pay for all inspections required by law. If the Seller fails to correct any violations of law, at the Seller's own expense, the Buyer may cancel this contract.

12. Property Lines. The Seller states that all buildings, driveways and other improvements on the Property are within its boundary lines. Also, no improvements on adjoining properties extend across the boundary lines of this Property, with the following exception: None.

13. Ownership. The Seller agrees to transfer and the Buyer agrees to accept ownership of the Property free of all claims and rights of others, except for:

- a. the rights of utility companies to maintain pipes, poles, cables and wires over, on and under the street, the part of the Property next to the street or running to any house or other improvements on the Property.

In addition to the above, the ownership of the Buyer must be insurable at regular rates by any title insurance company authorized to do business in New Jersey.

14. Correcting Defects. If the Property does not comply with Paragraph 13 of this contract, the Seller will be notified and given thirty (30) days to make it comply. If the Property still does not comply after that date, the Buyer may cancel this contract or give the Seller more time to comply.

15. Notices. All notices under this Contract must be in writing. The notices must be delivered personally or mailed by certified mail, return receipt requested, to the other party at the address written in this contract, or to that party's attorney.

16. Assessments for Municipal Improvements. Certain municipal improvements such as sidewalks and sewers may result in the municipality charging Property owners to pay for the improvement. All unpaid charges (assessments) against the Property for work completed before the closing will be paid by the Seller at or before the closing. If the improvement is not completed before the closing, then only the Buyer will be responsible. If the improvement is completed, but the amount of the charge (assessment) is not determined, the Seller will pay an estimated amount at the closing. When the amount of the charge is finally determined, the Seller will pay any deficiency to the Buyer (if the estimate proves to have been too low), or the Buyer will return any excess to the Seller (if the estimate proves to have been too high).

17. Adjustment at Closing. The Buyer and Seller agree to adjust the following expenses as of the closing date: municipal water and sewer charges. The Buyer or the Seller may require that any person with a claim or right affecting the Property be paid off from the proceeds of this sale. However, the parties understand that there are no such adjustments to be made as the property is presently vacant land.

18. Possession. As of the closing, Seller will retain possession of the property, pursuant to the terms of a Leasing and Management Agreement to be executed prior to or on the occasion of the closing, according to the form attached hereto as Schedule "B". No other Tenant will have any right to the property unless otherwise agreed to in this Contract.

19. Complete Agreement. This Contract is the entire and only agreement between the Buyer and the Seller. This Contract replaces and cancels any previous agreements between the Buyer and the Seller. This Contract can only be changed by an agreement

in writing signed by both Buyer and Seller. The Seller states that the Seller has not made any other Contract to sell the Property to anyone else.

20. Parties Liable. This Contract is binding upon all parties who sign it and all who succeed to their rights and responsibilities.

21. No Recording. This Agreement shall not be recorded without the written consent of all parties.

22. Easements. An easement is a privilege or right a person may have to use the land of another person. An example of this would be a right of way. The Seller warrants there are no existing easements (other than for public utilities) affecting this property except as follows: (describe) None

23. Closing Costs. Seller shall pay for the drawing of the bargain and sale deed and transfer tax required and 50% of the settlement fee; all searches, title insurance and other conveyancing expenses are to be paid by the Buyer.

24. Acreage. Buyer represents and Seller understands that Buyer's promise to purchase the property at the stipulated price is based on an assumption that the parcel consists of .32 acres, more or less. If, as a result of Buyer's survey, it is determined that the parcel is significantly smaller than anticipated (i.e., more than 10%), then Buyer shall have the right to void this Agreement on notice to Seller within 5 days of Buyer's receipt of the survey. However, no adjustment in the purchase price shall be made for a difference in acreage either greater or lesser than .32 acres.

25. ECRA/ISRA Compliance.

- (a) Seller shall execute an affidavit attesting to the non-applicability of the Industrial Site Recovery Act (ISRA). Said affidavit shall be executed by a duly authorized agent/representative of Seller. If the Seller does not execute said affidavit prior to or on the date of closing, then the County shall have the sole right to void this agreement on notice to the Seller. A copy of said affidavit is attached hereto as Schedule "C".
- (b) For purposes of this paragraph, the term "Environmental Documents" shall mean all environmental documentation in the possession or under the control of Seller concerning the premises or its environs, including without limitation all sampling plans, cleanup plans, sampling results, sampling result reports, data, diagrams, charts, maps, analyses, conclusions, quality assurance/quality control documentation, correspondence to or from the Industrial Site Evaluation Element or its successor ("Element") of the New Jersey Department of Environmental Protection or its successor ("NJDEP") or any other municipal, county, state or federal governmental authority, submissions to the Element or any other municipal, county, state or federal governmental authority and directives, orders, approvals and disapprovals issued by the Element or any other municipal, county, state or federal governmental authority. Within five days from the signing of this agreement, and subsequently promptly upon receipt by Seller or Seller's representatives, Seller shall deliver to the County: (i) all Environmental Documents concerning or generated by or on behalf of predecessors in title or former occupants of the premises; (ii) all Environmental Documents concerning or generated by or on behalf of Seller, whether currently or hereafter existing; (iii) all Environmental Documents concerning or generated by or on behalf of current or future occupants of the premises, whether currently or hereafter existing; and (iv) a description of all known operations, past and present, undertaken at the premises, and existing maps, diagrams and other Environmental Documents designating the location of past and present operations at the premises and past and present storage of hazardous or toxic substances, pollutants or wastes, or fill materials, above or below ground, in, on, under or about the premises or its environs.
- (c) The County and the County's agents and representatives shall have the right, without the obligation, prior to the closing of title, to enter upon the premises for the purpose of inspecting and performing testing at the

premises, including without limitation soil borings, groundwater investigation, percolation tests and engineering studies. Seller shall notify the County of any dangerous conditions on the premises, including without limitation conditions which due to the nature of the inspection or testing to be performed by or on behalf of the County may pose a dangerous condition to the County or the County's agents or representatives. If the County determines that the premises is in violation of law, that fill materials exist, or that hazardous or toxic substances, pollutants or wastes exist, or have been spilled, discharged or placed in, on, under or about the premises, then the County shall have the right to rescind this agreement on notice to Seller.

- (d) Seller shall notify the County in advance of all meetings scheduled between Seller or Seller's representatives and NJDEP, and the County and the County's representatives shall have the right, without the obligation, to attend and participate in all such meetings.

26. Seller's Compliance with Environmental Laws. Seller represents and warrants to Buyer that, to the best of Seller's knowledge, the property is in full compliance with all federal, state, county and municipal environmental laws, ordinances, rules, regulations and requirements and that there has not been a spill or discharge of a hazardous substance or a hazardous waste at the premises. In addition, Seller represents and warrants that it has taken no action during the period of its ownership which would result in noncompliance with the within-referenced laws.

27. Seller's Indemnification of Buyer (Environmental). Seller shall indemnify, defend and hold harmless Buyer from and against all claims, liabilities, losses, damages, penalties and costs, foreseen or unforeseen, including without limitation counsel, engineering and other professional or expert fees, which Buyer may incur, resulting directly or indirectly, wholly or partly from any misrepresentation or breach of warranty by Seller or by reason of Seller's action or non-action with regard to Seller's obligations under paragraphs 14, 25, 26, 30, 31 and 32.

28. Cancellation of Contract. Seller shall reimburse Buyer for the cost of title examination, surveys and appraisals in the event that this contract is cancelled in accordance with paragraphs 9, 14, 19, 24, 25, and 31. In any such instance, upon payment of this cost by Seller to Buyer, neither party shall be under any further obligation to the other.

29. Survival. All promises, warranties and representations within paragraphs 11, 12, 25, 26, 27, 30, 31, 32, and 33 shall survive the closing of title.

30. Removal of Trash/Personalty/Fixtures. Seller promises to remove from the property all trash, refuse, waste material, and personal property of any kind or description (including any and all sheds, trailers and similar structures or fixtures) prior to closing.

31. Environmental Audit. Buyer shall be entitled, at its own expense, to retain a qualified environmental consultant to conduct a Phase I environmental audit of the property. This audit, if commissioned by Buyer, shall be completed in accordance with American Society for Testing and Materials (ASTM) Standard Practice E1527-84 and with the Technical Requirements for Site Remediation found at NJAC 7:26E. Any such audit shall be completed within 90 days of the date when the last party signs this contract. Buyer, at its sole option, may cancel this contract based its on its dissatisfaction with the results of said audit by providing notice to Seller in writing within 30 days of its receipt of written audit results.

32. Condition of Tanks. Seller hereby warrants and represents that, to the best of Seller's knowledge, all tanks, if any, containing oil, gas or any other type of fuel or hazardous substance on the property have been removed, consistent with the Radiation Action Outcome and closure report prepared for the Seller and dated October 13, 2016.

33. Contingent on Execution of Leasing and Management Agreement. Buyer's obligation to close this purchase is specifically contingent on the execution by Seller of a Leasing and Management Agreement for the underlying Property according to the form attached hereto and made a part hereof as Schedule "B".

34. Buyer's Obligations. Subject to the conditions listed in a letter dated September 21, 2016 to Mr. Jim Mallon, Administrator:

1. Site remediation issues must be resolved, to the maximum extent practical, prior to acquisition.

2. For site remediation issues that cannot be resolved to the satisfaction of the County, or for those issues requiring ongoing monitoring and/or remediation, the City must take responsibility for any necessary actions.

3. The site will not be listed on the Green Acres Recreation and Open Space Inventory (ROSI).

35. Broker's Commission. Buyer and Seller represent that neither party has been involved with a real estate broker and that no commission is due to any real estate broker upon the closing of title. Both Parties agree that the purchase price set forth in this Agreement is based in part on the fact that no broker is entitled to a real estate commission relating to this sale. Buyer further agrees to hold Seller, Seller's successors and assigns, harmless from the claims of any real estate broker in connection with this Agreement of Sale or sale of the subject property to Buyer. Seller likewise agrees to hold Buyer harmless of all losses including court costs and attorney's fees and claims which result from inaccuracy of the representation that Seller was not involved with a real estate broker. The representations, indemnities and provisions of this paragraph shall survive the closing of title and shall not merge into the Deed delivered at closing.

36. Attorney Review. The County recommends that Seller consults with an attorney and submit this agreement to an attorney for review. In the event that Seller fails to submit this agreement to attorney review or if the Seller's attorney neither disapproves nor requests modification to this agreement within five days of Seller's execution hereof, Seller shall be bound hereby. Seller shall be responsible for the cost of any attorney they retain to represent or counsel them with respect to this matter.

37. Deed Restrictions. Since the property is being purchased with funds from the Open Space and Farmland Preservation Trust Fund, the Deed shall contain a restriction providing the premises shall be maintained in perpetuity as open space, as defined by the Open Space Act and any subsequent amendments.

SIGNED AND AGREED TO BY:

ATTEST:

CITY OF OCEAN CITY

MELISSA BOVERA
Municipal Clerk

By: _____(Seal)
JAY A. GILLIAN, SELLER
Mayor

Date: _____

ATTEST:

COUNTY OF CAPE MAY

ELIZABETH BOZZELLI
Clerk of the Board

By: _____(Seal)
GERALD M. THORNTON BUYER
Freeholder Director

Date: _____

APPROVED AS TO FORM:

JAMES B. ARSENAULT, JR., ESQ.
Assistant County Counsel

LEASING AND MANAGEMENT AGREEMENT

THIS AGREEMENT, made on this _____ day of _____, 2017, between THE COUNTY OF CAPE MAY (hereinafter referred to as "County"), whose offices are located at 4 Moore Road, Cape May Court House, New Jersey 08210, and THE CITY OF OCEAN CITY (hereinafter referred to as "City"), whose offices are located at 861 Asbury Avenue, Ocean City, New Jersey 08226.

WHEREAS, the City owns property identified as Block 811.01, Lot 3 in the City of Ocean City (the "Property"); and

WHEREAS, the City has affirmatively requested that the County consider purchasing Block 811.01, Lot 3, pursuant to the County's Open Space and Farmland Preservation Program; and

WHEREAS, this request was formalized in a document entitled "Open Space Application", dated July 1, 2016 and executed by Jim Mallon, Administrator for the City of Ocean City, a copy of which is attached hereto and made a part hereof as Exhibit "A" (the "Application"); and

WHEREAS, the referenced Application was recommended for approval by the County's Open Space Review Board; and

WHEREAS, the County and the City have negotiated a mutually agreeable purchase price; and

WHEREAS, the County's Board of Chosen Freeholders has authorized the acquisition of the referenced property, subject to the consummation of this present Agreement.

NOW, THEREFORE, in consideration of the mutual promises contained herein, the parties agree as follows:

1. All of the above recitals are incorporated herein by reference, as if repeated at length.
2. It is acknowledged by the City that the County has agreed to purchase this Property for the Open Space Program in specific reliance on the City's affirmative expressions of willingness to assume immediate and complete responsibility for the care, management, control, maintenance, insurance and general operation of the property and any future improvements (see #3 below). The County has not appropriated funds in the current fiscal year, nor does it intend to appropriate funds in subsequent years, for the care, custody, policing, management, control, maintenance, insurance and general operation

of the said Property, and it is anticipated that all such appropriations shall be forthcoming from the City, on an annual basis, in amounts reasonably suitable to the needs of the Property.

3. Effective as of the date and time of closing between the County and the City, this present Agreement shall constitute a lease of the said Property from the County (as Landlord) to the City (as Tenant), for a term of twenty-five years. The City shall have the option to renew this lease for an additional term of twenty-five years, provided that it notifies the County in writing of its desire to exercise this option at least six months prior to the termination of the original term, and further provided that it is not then in breach of any of its obligations under this Agreement.

4. In consideration for this lease, the City shall pay to the County the sum of \$1.00, and it shall also immediately undertake and assume complete responsibility for the care, management, control, maintenance and general operation, including payment for insurance and utilities of the subject Property (including all current and future improvements and fixtures thereon). It is the intent of this Agreement that the County shall have no financial obligations or liabilities whatsoever in connection with the Property, other than the obligation to fund the \$475,000.00 purchase of fee simple title in a manner and terms as dictated by the promissory. The City is required to adequately maintain the property. For special or limited time events, the City may fulfill some or all of its obligations under this paragraph by contracting for appropriate services with qualified and reputable third parties.

5. It is understood and agreed between the parties that title to this Property must, by statute, be held by the County in an Open Space, Recreation, and Farmland and Historic Preservation Trust and it is further understood that the Property must be used exclusively for purposes authorized under the governing legislation (N.J.S.A. 40:12-15.1, et seq).

6. It is further agreed that the City shall assume the obligations and prerogatives which would otherwise apply to the governing body of the County as owner of the Property. In particular, it is understood that:

- a) The City shall annually appropriate such amounts as it may deem necessary for the care, custody, policing, and maintenance of the Property (including improvements), and provide the County Planning Department with documentation of the annual maintenance budget of this facility; and
- b) Subject to the restrictions of the Open Space and Farmland Preservation Program, the City shall have full control of the Property and all recreational functions and may enact local

legislation providing for suitable rules, regulations and by-laws for its use, and providing also for the enforcement thereof; and

- c) The City may, when appropriate, enact local legislation imposing charges and collecting reasonable fees for the use of the Property or for activities conducted thereon.

However, enactments by the City under subparagraphs (b) and (c), above, with the exception of determination of recreational use, shall be subject to the approval of the governing body of the County, or its designee, which approval shall not be unreasonably withheld. Any such enactments shall not become effective until the governing body of the County adopts a Resolution consenting to same.

7. The City agrees to operate, improve and maintain the Property in a manner which is at all times and in every way consistent with the definition of "Recreation and Conservation Purposes" articulated in N.J.S.A. 40:12-15.1. The City shall obtain the approval of the governing body of the County, or its designee, before effecting the alteration, demolition or construction of any improvements or fixtures on the property. The County's consent shall not be unreasonably withheld.

8. Upon completion of the project, the City is required to install a permanent marker or plaque recognizing the collaborative partnership between the City and the County and acknowledging funding through the Cape May County Open Space & Farmland Preservation Trust Fund. The signage will be in a manner and template form approved and provided by the County and the Cape May County Open Space Review Board.

Any sponsorship signage, such as

- (a) "permanent/structural" items (i.e., baseball scoreboard, pressbox, embedded logo on turf field); and
- (b) temporary signage (i.e., banners on outfield fences)

displayed at the recreation area shall require

- (a) a list of intended sponsors; and
- (b) approval by the Open Space Review Board and/or Freeholder Board, which shall not be unreasonably withheld, conditioned or delayed.

9. The City agrees to indemnify the County and to hold it harmless from and against any and all damages, claims, losses, liabilities of any sort, judgments, suits or demands at law or equity (including reasonable attorney's

fees), arising out of the use, occupancy, operation and maintenance of this Property by the City or by any of the City's agents, officers, employees, servants or contractors. The City further agrees that it shall name annually the County as an additional primary insured on a general liability insurance policy annually with coverage at least equal to \$3 million per bodily injury or property damage occurrence, in order to effectuate the defense and indemnity provisions set forth above. It is the parties' intention that this Agreement shall be interpreted to be broad in nature, whereby each party agrees to indemnify the other for its own acts unless it is determined that one party alone was solely negligent.

10. In the event that the City ceases to operate and maintain the Property in a manner consistent with this Agreement and with the terms and provisions of N.J.S.A. 40:12-15.1, et seq.), during the term of this lease, or any renewals hereof, the County may, at its option, either:

- a) Bring an action for specific performance of this Agreement (it being hereby stipulated by the parties that the subject matter of this Agreement is of such a special nature that legal remedies for a breach are inadequate); or
- b) Declare this Agreement to be terminated, at which point the City shall have no further rights with respect to the Property and shall surrender possession of same, including any improvements, to the County.

11. Notices under this Agreement shall be in writing and shall be forwarded as follows:

- a) As to the City:
City Clerk
City of Ocean City
861 Asbury Avenue
Ocean City, New Jersey 08226

With a copy to the City Solicitor, care of the same address;
and

- b) As to the County:
Clerk of the Board
County of Cape May
4 Moore Road
Cape May Court House, New Jersey 08210.

With a copy to the County Counsel, care of the same address.

IN WITNESS WHEREOF, the parties affix their signatures to this Agreement, intending to be legally bound. If a party is a corporation, this Agreement is signed by its proper corporate officers and its corporate seal is affixed.

ATTEST:

COUNTY OF CAPE MAY

Elizabeth Bozzelli
Clerk of the Board

By:

Gerald M. Thornton
Freeholder Director

Date: _____

APPROVED AS TO FORM:

James B. Arsenault, Jr., Esq.
County Counsel

ATTEST:

CITY OF OCEAN CITY

Melissa Bovera
Municipal Clerk

By:

Jay A. Gillian
Mayor

Date: _____

CITY OF OCEAN CITY
CAPE MAY COUNTY, NEW JERSEY

RESOLUTION

#13

AUTHORIZING THE PAYMENT OF CLAIMS

WHEREAS, N.J.S.A. 40A: 5-17 entitled "Approval and Payment of Claims and Required General Books of Account" generally sets forth the manner in which claims against municipalities are to be handled; and

WHEREAS, the attached bill list represent claims against the municipality for period including September 9, 2017 to September 22 , 2017

WHEREAS, the attached PCARD check register represents paid claims against the municipality for the period of July 1, 2017 to July 31, 2017

NOW, THEREFORE, BE IT RESOLVED that the attached bill list is approved for payment.



Frank Donato III
Chief Financial Officer



Peter V. Madden
Council President

FILES/AUTHORIZING THE PAYMENT OF CLAIMS - 09.09.17 TO 09.22.17.doc

Offered by Seconded by

The above resolution was duly adopted by the City Council of the City of Ocean City, New Jersey, at a meeting of said Council duly held on the day of 2017.

NAME	AYE	NAY	ABSENT	ABSTAINED
Barr	_____	_____	_____	_____
Bergman	_____	_____	_____	_____
DeVlieger	_____	_____	_____	_____
Hartzell	_____	_____	_____	_____
Madden	_____	_____	_____	_____
McClellan	_____	_____	_____	_____
Wilson	_____	_____	_____	_____

.....
City Clerk

PO #	PO Date	Vendor	PO Description	Status	Amount	Void Amount	PO Type
17-00855	04/11/17	RMAXWELL R. MAXWELL CONST. CO., INC.	RES 17-53-100; CC #17-25	Open	85,781.24	0.00	B
17-00875	04/12/17	AGUZZO A. GUZZO LANDSCAPING LLC	CITY CONTRACT 17-18	Open	420.00	0.00	
17-00900	04/19/17	GOVDEALS GOV DEALS	GOVDEAL AUCTION FEES 2017	Open	686.00	0.00	
17-00987	05/02/17	OCHUM OCEAN CITY HUMANE SOCIETY	2017 ALLOTMENT RES# 15-51-032	Open	8,224.50	0.00	
17-00989	05/02/17	JLLAWSON J L LAWSON COMPANY INC	Quarterly Maintenance	Open	282.65	0.00	B
17-01020	05/05/17	SCHIAVON FRED M. SCHIAVONE CONST., INC.	RES 17-53-130, CC 17-29	Open	40,624.92	0.00	C
		Contract No: 00001729					
17-01021	05/05/17	FRALING FRALINGER ENGINEERING PA	RES# 16-52-257	Open	250.85	0.00	
17-01117	05/10/17	LATECH LATECH CONSULTING, INC.	SOFTWARE SERVICE	Open	900.00	0.00	
17-01137	05/12/17	LUMBERMA LUMBERMAN ASSOCIATES	RES 17-53-144 / CC#17-31	Open	36,817.60	0.00	
17-01345	05/30/17	IPSGROUP IPS GROUP CORPORATION	NCPA 05-14	Open	74,146.54	0.00	B
17-01401	06/06/17	PEPSI THE PEPSI BOTTLING COMPANY	SODA WATER JUICE FOR RESALE	Open	287.61	0.00	B
17-01487	06/15/17	OCART OCEAN CITY ARTS CENTER	2017 REIMBURSEMENTS	Open	6,849.29	0.00	
17-01489	06/15/17	RAYPALME RAY PALMER ASSOCIATES, INC.	RES 17-53-170; CC:17-40, 2017	Open	141,610.00	0.00	B
17-01576	06/16/17	SENTI SENTINEL LEDGER	2017 SENTINEL LEDGER ADS	Open	5,043.20	0.00	
17-01609	06/21/17	SEASHORE SEASHORE ASPHALT CORP.		Open	535.98	0.00	B
17-01616	06/22/17	BOSSEVEN BOSS EVENTS, LLC	HALF MARATHON	Open	4,619.60	0.00	
17-01621	06/23/17	GYMSOUR GYM SOURCE		Open	2,626.40	0.00	
17-01675	07/11/17	TACPRINT TAC PRINTING AND MARKETING		Open	2,640.00	0.00	
17-01690	07/11/17	WIREL WIRELESS ELECTRONICS INC.		Open	2,667.06	0.00	
17-01718	07/13/17	KDI KEYSTONE DIGITAL IMAGING, INC	CONTRACT NUMBER: 18055	Open	19,980.00	0.00	
17-01728	07/13/17	COASTALL COASTAL LANDSCAPEING	RES 17-53-204	Open	1,359.90	0.00	
17-01746	07/13/17	SEASISLE CITY OF SEA ISLE CITY	RES 16-52-367 SHARED SERVICES	Open	1,980.00	0.00	
17-01747	07/13/17	DEPT DEPTCOR	STATIONERY	Open	2,914.50	0.00	
17-01811	07/21/17	PRIMIANO MARILYN PRIMIANO		Open	150.00	0.00	
17-01834	07/28/17	GANN GANN LAW BOOKS, INC.		Open	152.00	0.00	
17-01849	08/01/17	CAPRI CAPRIONI PORTABLE TOILETS, INC		Open	65.00	0.00	
17-01983	08/03/17	CONSOL S CONSOLIDATED STEEL & ALUMINUM	St Cont: #A88680 T#: T0640	Open	38,475.00	0.00	
17-01996	08/03/17	HORIN BILL HORIN PHOTOGRAPHY		Open	4,000.00	0.00	B
17-01997	08/03/17	MCCUSKER ERIN MCCUSKER		Open	5,000.00	0.00	
17-02046	08/11/17	CENTRALT CENTRAL TURF & IRRIGATION SUPP		Open	1,372.00	0.00	
17-02054	08/11/17	BLONDIES BLONDIE'S FLOATS		Open	2,250.00	0.00	
17-02077	08/17/17	NJSLOM NJ STATE LEAGUE OF	CONFERENCE REGISTRATION	Open	110.00	0.00	
17-02113	08/23/17	EASTERNS EASTERNS SURPLUS & EQUIP., CO	Storm Truck Parts	Open	3,820.00	0.00	
17-02219	08/30/17	MCAA MCAA OF NEW JERSEY		Open	140.00	0.00	
17-02222	08/30/17	KENNELL MADISON KENNELLY		Open	2,500.00	0.00	
17-02238	08/30/17	NJSSC NEW JERSEY STATE SAFETY		Open	35.00	0.00	
17-02241	08/30/17	NJSAC NJ STATE ASSOCIATION OF CHIEFS		Open	1,667.00	0.00	
17-02242	08/30/17	ACTIONUN ACTION UNIFORM CO., L.L.C	RES 15-51-315	Open	1,414.00	0.00	
17-02248	08/30/17	SPINN SPINNING WHEEL FLORIST INC.		Open	548.00	0.00	
17-02262	09/05/17	NJSLOM NJ STATE LEAGUE OF	CONFERENCE REGISTRATION	Open	165.00	0.00	
17-02269	09/05/17	SEASISLE CITY OF SEA ISLE CITY	RES #17-53-225 SHARED SERVICES	Open	11,905.95	0.00	
17-02271	09/05/17	AIRPO AIRPOWER INTERNATIONAL, INC.		Open	3,975.75	0.00	
17-02276	09/05/17	NJSLOM NJ STATE LEAGUE OF	League Conference 11/14-11/16	Open	165.00	0.00	
17-02279	09/05/17	USLA U.S.L.A.-NJ CERTIFICATION		Open	150.00	0.00	
17-02281	09/05/17	SJOVE SOUTH JERSEY OVERHEAD DOOR CO.		Open	1,750.00	0.00	
17-02286	09/11/17	JUSTR JUST RIGHT TV PRODUCTIONS LLC		Open	600.00	0.00	
17-02287	09/11/17	FAVERZA NORA FAVERZANI		Open	750.00	0.00	
17-02289	09/11/17	ROSENA ALEXA PAIGE ROSEN		Open	250.00	0.00	
17-02290	09/11/17	FRIEN FRIENDS OF THE POPS		Open	6,288.25	0.00	
17-02292	09/11/17	AC ELECT ATLANTIC CITY ELECTRIC		Open	1,978.79	0.00	
17-02293	09/11/17	ANJR ASSOCIATION OF NEW JERSEY		Open	50.00	0.00	
17-02294	09/11/17	NJSLOM NJ STATE LEAGUE OF		Open	440.00	0.00	
17-02295	09/11/17	SONJ5 TREASURER STATE OF NEW JERSEY		Open	76.00	0.00	

PO #	PO Date	Vendor	PO Description	Status	Amount	Void Amount	PO Type
17-02300	09/11/17	BINSI	BERBEN INSIGNIA CO.	Open	876.50	0.00	
17-02302	09/11/17	ACTIONUN	ACTION UNIFORM CO., L.L.C	Open	166.00	0.00	
17-02303	09/11/17	RHINO	RHINO LININGS	rhino line 17-17 F250 Utility	Open	700.00	0.00
17-02304	09/11/17	MONMOUT	MONMOUTH TRUCK EQUIPMENT	Headache rack for Utility body	Open	689.00	0.00
17-02305	09/11/17	AERIALTE	AERIAL TESTING COMPANY LLC		Open	4,153.00	0.00
17-02306	09/11/17	SJCAA	SOUTH JERSEY COURT ADMIN ASSN.		Open	90.00	0.00
17-02308	09/13/17	JWR CONS	JWR PROPERTIES INC.	ESCROW REFUND	Open	122.00	0.00
17-02309	09/13/17	MCHUGHCH	CHARLES MCHUGH	ESCROW REFUND	Open	661.24	0.00
17-02310	09/13/17	HYLAN	HYLAND DESIGN GROUP, INC.	ESCROW REFUND	Open	28.96	0.00
17-02311	09/13/17	HILLA	ANDREW HILL	ESCROW REFUND	Open	350.46	0.00
17-02312	09/13/17	VANDERHE	GEORGE VANDERHEYDEN	ESCROW REFUND	Open	955.88	0.00
17-02314	09/14/17	OICORELO	CORELOGIC TAX SERVICES	TAX OVERPAYMENT REFUND 2017-15	Open	1,477.80	0.00
17-02315	09/14/17	OICORELO	CORELOGIC TAX SERVICES	TAX OVERPAYMENT REFUND 2017-16	Open	74.45	0.00
17-02316	09/14/17	OICORELO	CORELOGIC TAX SERVICES	TAX OVERPAYMENT REFUND 2017-17	Open	737.83	0.00
17-02317	09/14/17	POSTORIV	ALCIDE & LINDA POSTORIVO	ESCROW REFUND	Open	359.56	0.00
17-02318	09/14/17	RODAKD	DAVID RODAK	ESCROW REFUND	Open	43.60	0.00
17-02319	09/14/17	PERUGINI	ELIZABETH PERUGINI	ESCROW REFUND	Open	1,082.02	0.00
17-02320	09/14/17	NAPOLET	CLAUDE NAPOLETANO	ESCROW REFUND	Open	219.76	0.00
17-02321	09/14/17	GEISEJAM	JAMES GEISE	ESCROW REFUND	Open	1,552.44	0.00
17-02322	09/14/17	BEIDEMAN	FRANK BEIDEMAN	ESCROW REFUND	Open	433.36	0.00
17-02323	09/14/17	KELLERS	SHARON KELLER	ESCROW REFUND	Open	100.00	0.00
17-02324	09/14/17	MURTHAT	TIMOTHY MURTHA	ESCROW REFUND	Open	919.55	0.00
17-02325	09/14/17	CACCIUTT	JOHN CACCIUTTI	ESCROW REFUND	Open	1,103.36	0.00
17-02326	09/14/17	SEGICHK	KEVIN SEGICH	ESCROW REFUND	Open	147.02	0.00
17-02327	09/14/17	BARRP	PAUL BARR	ESCROW REFUND	Open	79.02	0.00
17-02328	09/14/17	DIPASQUA	DONNA DIPASQUALE	ESCROW REFUND	Open	156.84	0.00
17-02329	09/15/17	EASTS	EASTERN SIGN CO		Open	40.00	0.00
17-02330	09/15/17	CENTRAL	CENTRAL JERSEY EQUIPMENT		Open	138.31	0.00
17-02331	09/15/17	CODYS	CODY'S POWER EQUIPMENT		Open	305.05	0.00
17-02332	09/15/17	SHOEM	SHOEMAKER LUMBER COMPANY, INC		Open	77.04	0.00
17-02333	09/15/17	WALSH M	MICHAEL WALSH		Open	476.65	0.00
17-02334	09/15/17	SANTO	SANTORI'S PRODUCE		Open	87.00	0.00
17-02339	09/15/17	NJSLOM	NJ STATE LEAGUE OF		Open	190.00	0.00
17-02341	09/15/17	HARTMAN	MICHAEL J. HARTMAN		Open	14.39	0.00
17-02348	09/15/17	REGIT	REGISTRARS' ASSOCIATION OF NJ		Open	225.00	0.00
17-02360	09/19/17	NAPAAUTO	SEAVILLE NAPA AUTO PARTS	NJPA031212GPC	Open	853.77	0.00
17-02361	09/19/17	NAPAAUTO	SEAVILLE NAPA AUTO PARTS		Open	121.47	0.00
17-02362	09/19/17	CHAPMAN	CHAPMAN FORD LINCOLN MERCURY	79166	Open	40.92	0.00
17-02378	09/20/17	NORTHST	NORTHSTAR APPRASIAL COMPANY	APPRAISAL BLK 70.41, LOT 2,3	Open	6,500.00	0.00
17-02487	09/25/17	NERZMICH	MICHAEL NERZ		Open	100.00	0.00

Total Purchase Orders: 143 Total P.O. Line Items: 0 Total List Amount: 838,358.25 Total Void Amount: 0.00

September 21, 2017
08:54 AM

CITY OF OCEAN CITY
Check Register By Check Id

July 2017 PCARDS

Range of Checking Accts: GENERAL to GENERAL Range of Check Ids: 8574 to 8659
Report Type: All Checks Report Format: Detail Check Type: Computer: Y Manual: Y Dir Deposit: Y

Check #	Check Date	Vendor	Amount Paid	Charge Account	Account Type	Reconciled/Void	Ref Num
PO #	Item	Description				Contract	Ref Seq Acct
8574	09/20/17	BOAPCARD BANK OF AMERICA					4238
17-02384	1	#02649 ACME - Purchase	90.95	7-01-20-090-267	Budget		1 1
				C/S-PUBLIC RELATIONS & INFO	CW PROMOTNS		
17-02384	2	#02649 ACME - Purchase	163.34	7-01-20-650-275	Budget		2 1
				FINANCIAL MGMT/REV COLLECTION-SAFETY			
17-02384	3	#02649 ACME - Purchase	1,103.33	7-01-20-090-267	Budget		3 1
				C/S-PUBLIC RELATIONS & INFO	CW PROMOTNS		
17-02384	4	#02649 ACME - Purchase	111.83	T-12-56-173-034	Budget		4 1
				REC. TRUST - SPECIAL EVENTS/RECREATION			
			<u>1,469.45</u>				
8575	09/20/17	BOAPCARD BANK OF AMERICA					4238
17-02385	1	ACTIVE911 INC - Purchase	1,068.75	7-01-25-770-211	Budget		5 1
				PS/PROFESSIONAL SERVICES			
8576	09/20/17	BOAPCARD BANK OF AMERICA					4238
17-02386	1	AED SUPERSTORE - Credit	5.80	7-01-20-098-259	Budget		6 1
				C/S-AQUATIC & FITNESS MINOR APPARATUS			
17-02386	2	AED SUPERSTORE - Purchase	90.23	7-01-20-098-259	Budget		7 1
				C/S-AQUATIC & FITNESS MINOR APPARATUS			
			<u>84.43</u>				
8577	09/20/17	BOAPCARD BANK OF AMERICA					4238
17-02387	1	AMAZON MKTPLACE PMTS - Purchas	19.63	7-01-20-040-265	Budget		8 1
				ADMIN/EMERGENCY MGMT-MINOR APP & EQUIP			
17-02387	2	Amazon.com - Purchase	190.36	7-01-20-101-259	Budget		9 1
				C/S-MUSIC PIER OPERATIONS MINOR APPRATUS			
17-02387	3	AMAZON MKTPLACE PMTS - Purchas	232.89	7-01-20-040-265	Budget		10 1
				ADMIN/EMERGENCY MGMT-MINOR APP & EQUIP			
17-02387	4	AMAZON MKTPLACE PMTS - Purchas	319.94	7-01-20-101-259	Budget		11 1
				C/S-MUSIC PIER OPERATIONS MINOR APPRATUS			
17-02387	5	AMAZON MKTPLACE PMTS - Purchas	24.07	7-01-25-740-233	Budget		12 1
				PS/POLICE-EQUIP MAINT&REPAIR			
17-02387	6	AMAZON MKTPLACE PMTS - Purchas	26.36	7-01-25-740-233	Budget		13 1
				PS/POLICE-EQUIP MAINT&REPAIR			
17-02387	7	AMAZON.COM AMZN.COM/BILL - Pur	29.99	7-01-25-740-233	Budget		14 1
				PS/POLICE-EQUIP MAINT&REPAIR			
17-02387	8	AMAZON.COM AMZN.COM/BILL - Pur	104.65	7-01-25-740-233	Budget		15 1
				PS/POLICE-EQUIP MAINT&REPAIR			
17-02387	9	AMAZON MKTPLACE PMTS - Purchas	330.49	C-04-55-301-506	Budget		16 1
				PICKUP TRUCK - FIRE DEPT. 4X4 BEACH			
17-02387	10	AMAZON MKTPLACE PMTS - Purchas	101.93	T-12-56-173-033	Budget		17 1
				RECREATION TRUST PROGRAMS			
			<u>1,380.31</u>				
8578	09/20/17	BOAPCARD BANK OF AMERICA					4238
17-02388	1	AMERICAN AIR0012137681255 - Pu	2,708.40	7-01-20-090-267	Budget		18 1
				C/S-PUBLIC RELATIONS & INFO	CW PROMOTNS		

Check #	Check Date	Vendor	Amount Paid	Charge Account	Account Type	Reconciled/Void		Ref Num
						Contract	Ref Seq	
8579	09/20/17	BOAPCARD BANK OF AMERICA						4238
17-02389	1	IBI - SUPPLYWORKS #2251 - Purc	1,718.27	7-01-25-770-259 PS/FIRE-MINOR APPARATUS	Budget			19 1
17-02389	2	IBI - SUPPLYWORKS #2251 - Purc	0.12	7-01-26-825-259 CITY WIDE - MINOR APPARATUS	Budget			20 1
17-02389	3	IBI - SUPPLYWORKS #2251 - Purc	57.75	7-01-26-825-259 CITY WIDE - MINOR APPARATUS	Budget			21 1
17-02389	4	IBI - SUPPLYWORKS #2251 - Purc	142.92	7-01-26-825-259 CITY WIDE - MINOR APPARATUS	Budget			22 1
17-02389	5	IBI - SUPPLYWORKS #2251 - Purc	266.00	7-01-26-825-259 CITY WIDE - MINOR APPARATUS	Budget			23 1
17-02389	6	IBI - SUPPLYWORKS #2251 - Purc	274.56	7-01-26-825-259 CITY WIDE - MINOR APPARATUS	Budget			24 1
17-02389	7	IBI - SUPPLYWORKS #2251 - Purc	288.75	7-01-26-825-259 CITY WIDE - MINOR APPARATUS	Budget			25 1
17-02389	8	IBI - SUPPLYWORKS #2251 - Purc	383.00	7-01-26-825-259 CITY WIDE - MINOR APPARATUS	Budget			26 1
17-02389	9	IBI - SUPPLYWORKS #2251 - Purc	461.57	7-01-26-825-259 CITY WIDE - MINOR APPARATUS	Budget			27 1
17-02389	10	IBI - SUPPLYWORKS #2251 - Purc	652.62	7-01-26-825-259 CITY WIDE - MINOR APPARATUS	Budget			28 1
17-02389	11	IBI - SUPPLYWORKS #2251 - Purc	1,093.32	7-01-26-825-259 CITY WIDE - MINOR APPARATUS	Budget			29 1
17-02389	12	IBI - SUPPLYWORKS #2251 - Purc	1,327.41	7-01-26-825-259 CITY WIDE - MINOR APPARATUS	Budget			30 1
17-02389	13	IBI - SUPPLYWORKS #2251 - Purc	3,811.94	7-01-26-825-259 CITY WIDE - MINOR APPARATUS	Budget			31 1
17-02389	14	IBI - SUPPLYWORKS #2251 - Purc	4,303.21	7-01-26-825-259 CITY WIDE - MINOR APPARATUS	Budget			32 1
17-02389	15	IBI - SUPPLYWORKS #2251 - Purc	5,338.86	7-01-26-825-259 CITY WIDE - MINOR APPARATUS	Budget			33 1
17-02389	16	IBI - SUPPLYWORKS #2251 - Purc	5,360.43	7-01-26-825-259 CITY WIDE - MINOR APPARATUS	Budget			34 1
			<u>25,480.73</u>					
8580	09/20/17	BOAPCARD BANK OF AMERICA						4238
17-02390	1	ANNARELLIS BICYCLES - Purchase	366.90	7-01-26-820-259 SANITATION & RECEIVING - MINOR APPRATUS	Budget			35 1
8581	09/20/17	BOAPCARD BANK OF AMERICA						4238
17-02391	1	ATLANTIC IRRIGATION SPE - Irri	1,308.78	c-04-55-281-206 GENERAL	Budget			36 1
8582	09/20/17	BOAPCARD BANK OF AMERICA						4238
17-02392	1	AUSTINS SPORTS CENTER - Purcha	729.00	7-01-26-820-243 SANITATION & RECEIVING - UNIFORMS	Budget			37 1
8583	09/20/17	BOAPCARD BANK OF AMERICA						4238
17-02393	1	AUTOZONE #4706 - Purchase	53.43	7-01-20-040-265 ADMIN/EMERGENCY MGMT-MINOR APP & EQUIP	Budget			38 1

Check #	Check Date	Vendor	Amount Paid	Charge Account	Account Type	Reconciled/Void Contract	Ref Num	Ref Seq	Acct
8584	09/20/17	BOAPCARD BANK OF AMERICA					4238		
17-02394	1	B&H PHOTO MOTO - Purchase	881.90	C-04-55-299-301	Budget		39	1	
				COMMUNICATION UPGRADES					
17-02394	2	B&H PHOTO 800-606-6969 - Credit	50.93	7-01-25-745-259	Budget		40	1	
17-02394	3	B&H PHOTO 800-606-6969 - Purch	791.73	7-01-25-745-259	Budget		41	1	
				PS/INFO TECHNOLOGY-MINOR APPARATUS					
17-02394	4	B&H PHOTO MOTO - Purchase	189.47	7-01-25-745-259	Budget		42	1	
				PS/INFO TECHNOLOGY-MINOR APPARATUS					
			<u>1,812.17</u>						
8585	09/20/17	BOAPCARD BANK OF AMERICA					4238		
17-02395	1	MILLEVOI BEST TIRE INC - Purch	812.12	7-01-26-880-262	Budget		43	1	
				FLEET MAINTENANCE - TIRES					
8586	09/20/17	BOAPCARD BANK OF AMERICA					4238		
17-02396	1	BRICKS R US - Purchase	19.00	T-12-56-173-023	Budget		44	1	
				RECREATION TRUST- CREATE A MEMORY					
17-02396	2	BRICKS R US - Purchase	19.00	T-12-56-173-023	Budget		45	1	
				RECREATION TRUST- CREATE A MEMORY					
17-02396	3	BRICKS R US - Purchase	24.00	T-12-56-173-013	Budget		46	1	
				REC TRUST - MEM. PARK PAVER PROGRAM 2010					
			<u>62.00</u>						
8587	09/20/17	BOAPCARD BANK OF AMERICA					4238		
17-02397	1	BSN SPORT SUPPLY GROUP - Purch	155.00	7-01-20-099-259	Budget		47	1	
				C/S-RECREATIONAL PROGRAMS MINR APPARATUS					
17-02397	2	BSN SPORT SUPPLY GROUP - Tenni	475.75	7-01-26-830-268	Budget		48	1	
				FACILITY MAINTENANCE - GROUNDS KEEPING					
			<u>630.75</u>						
8588	09/20/17	BOAPCARD BANK OF AMERICA					4238		
17-02398	1	CDW GOVT #JDP2985 - Purchase s	2,376.00	C-04-55-299-301	Budget		49	1	
				COMMUNICATION UPGRADES					
17-02398	2	CDW GOVT #JPD5948 - Purchase	2,604.00	C-04-55-299-301	Budget		50	1	
				COMMUNICATION UPGRADES					
17-02398	3	CDW GOVT #JPD5950 - Purchase	2,999.94	C-04-55-299-301	Budget		51	1	
				COMMUNICATION UPGRADES					
17-02398	4	CDW GOVT #JDP2985 - Purchase s	3,200.00	C-04-55-259-301	Budget		52	1	
				GARDENS PARKWAY IMPROVEMENTS					
17-02398	5	CDW GOVT #JDP2985 - Purchase s	3,636.00	C-04-55-299-301	Budget		53	1	
				COMMUNICATION UPGRADES					
17-02398	6	CDW GOVT #JDP2985 - Purchase s	4,120.00	C-04-55-299-301	Budget		54	1	
				COMMUNICATION UPGRADES					
			<u>18,935.94</u>						
8589	09/20/17	BOAPCARD BANK OF AMERICA					4238		
17-02399	1	CHEAP CYCLE PARTS - Purchase	111.30	7-01-25-740-259	Budget		55	1	
				PS/POLICE-MINOR APPARATUS					
17-02399	2	CHEAP CYCLE PARTS - Purchase	682.84	7-01-25-730-259	Budget		56	1	
				PS/LIFEGUARDS-MINOR APPARATUS					
			<u>794.14</u>						

Check #	Check Date	Vendor	Amount Paid	Charge Account	Account Type	Reconciled/Void Contract	Ref Num
PO #	Item	Description					Seq Acct
8590	09/20/17	BOAPCARD BANK OF AMERICA					4238
17-02400	1	CAPE MAY COUNTY PARK - Purchas	80.00	T-12-56-173-033	Budget		57 1
				RECREATION TRUST PROGRAMS			
8591	09/20/17	BOAPCARD BANK OF AMERICA					4238
17-02401	1	CODYS POWER EQUIPMENT - Edger	480.64	7-01-26-830-268	Budget		58 1
				FACILITY MAINTENANCE - GROUNDS KEEPING			
8592	09/20/17	BOAPCARD BANK OF AMERICA					4238
17-02402	1	COLONIAL ELECTRIC SUPPLY - Pur	19.58	7-01-26-830-259	Budget		59 1
				FACILITY MAINTENANCE - MINOR APPARATUS			
17-02402	2	COLONIAL ELECTRIC SUPPLY - Pur	119.94	7-01-26-830-259	Budget		60 1
				FACILITY MAINTENANCE - MINOR APPARATUS			
17-02402	3	COLONIAL ELECTRIC SUPPLY - Pur	266.00	C-04-55-301-303	Budget		61 1
				29TH STREET FIRE HOUSE CONTENTS			
			<u>405.52</u>				
8593	09/20/17	BOAPCARD BANK OF AMERICA					4238
17-02403	1	COMCAST - Purchase	50.57	7-01-25-740-265	Budget		62 1
				PS/POLICE-EQUIPMENT OUTLAY			
17-02403	2	COMCAST - Purchase	72.00	7-01-25-740-265	Budget		63 1
				PS/POLICE-EQUIPMENT OUTLAY			
17-02403	3	COMCAST - Purchase	153.50	7-01-25-740-265	Budget		64 1
				PS/POLICE-EQUIPMENT OUTLAY			
17-02403	4	COMCAST - Purchase	244.67	7-01-25-745-265	Budget		65 1
				PS/INFO TECHNOLOGY-EQUIPMENT OUTLAY			
17-02403	5	COMCAST - Purchase	271.76	7-01-25-745-265	Budget		66 1
				PS/INFO TECHNOLOGY-EQUIPMENT OUTLAY			
17-02403	6	COMCAST - Purchase	285.71	7-01-25-745-265	Budget		67 1
				PS/INFO TECHNOLOGY-EQUIPMENT OUTLAY			
17-02403	7	COMCAST - Purchase	387.14	7-01-25-745-265	Budget		68 1
				PS/INFO TECHNOLOGY-EQUIPMENT OUTLAY			
17-02403	8	COMCAST - Purchase	387.14	7-01-25-745-265	Budget		69 1
				PS/INFO TECHNOLOGY-EQUIPMENT OUTLAY			
17-02403	9	COMCAST - Purchase	421.08	7-01-25-745-265	Budget		70 1
				PS/INFO TECHNOLOGY-EQUIPMENT OUTLAY			
17-02403	10	COMCAST - Purchase	444.05	7-01-25-745-265	Budget		71 1
				PS/INFO TECHNOLOGY-EQUIPMENT OUTLAY			
17-02403	11	COMCAST - Purchase	465.37	7-01-25-745-265	Budget		72 1
				PS/INFO TECHNOLOGY-EQUIPMENT OUTLAY			
			<u>3,182.99</u>				
8594	09/20/17	BOAPCARD BANK OF AMERICA					4238
17-02404	1	COMCAST UPWARE/Carboni - Purch	22.39	7-01-25-740-265	Budget		73 1
				PS/POLICE-EQUIPMENT OUTLAY			
8595	09/20/17	BOAPCARD BANK OF AMERICA					4238
17-02405	1	EVO STUDIOS, INC. EVO - Purcha	150.00	7-01-25-745-265	Budget		74 1
				PS/INFO TECHNOLOGY-EQUIPMENT OUTLAY			
17-02405	2	EVO STUDIOS, INC. EVO - Purcha	155.00	7-01-25-745-265	Budget		75 1
				PS/INFO TECHNOLOGY-EQUIPMENT OUTLAY			
			<u>305.00</u>				

Check #	Check Date	Vendor	Amount Paid	Charge Account	Account Type	Reconciled/Void Contract	Ref Num	Ref Seq	Acct
8596	09/20/17	BOAPCARD BANK OF AMERICA					4238		
17-02406	1	FARM RITE INC HAMMONTON - Purc	1,078.69	7-01-26-880-259	Budget		76	1	
				FLEET MAINTENANCE - MINOR APPARATUS					
8597	09/20/17	BOAPCARD BANK OF AMERICA					4238		
17-02407	1	FASTENAL COMPANY01 - Credit	16.00	7-01-26-840-259	Budget		77	1	
				FIELD OPERATIONS - MINOR APPARATUS					
17-02407	2	FASTENAL COMPANY01 - Purchase	19.85	7-01-26-840-259	Budget		78	1	
				FIELD OPERATIONS - MINOR APPARATUS					
17-02407	3	FASTENAL COMPANY01 - Purchase	234.99	7-01-26-840-259	Budget		79	1	
				FIELD OPERATIONS - MINOR APPARATUS					
17-02407	4	FASTENAL COMPANY01 - Purchase	4,053.21	C-04-55-297-201	Budget		80	1	
				ISOLATED REPLACEMENTS					
			4,292.05						
8598	09/20/17	BOAPCARD BANK OF AMERICA					4238		
17-02408	1	JOTFORM INC. - Purchase	159.00	7-01-25-745-265	Budget		81	1	
				PS/INFO TECHNOLOGY-EQUIPMENT OUTLAY					
8599	09/20/17	BOAPCARD BANK OF AMERICA					4238		
17-02409	1	FULL COMPASS SYS VT - Purchase	1,135.00	7-01-20-101-259	Budget		82	1	
				C/S-MUSIC PIER OPERATIONS MINOR APPRATUS					
8600	09/20/17	BOAPCARD BANK OF AMERICA					4238		
17-02410	1	Gamma Sports - Purchase	716.18	T-12-56-173-033	Budget		83	1	
				RECREATION TRUST PROGRAMS					
8601	09/20/17	BOAPCARD BANK OF AMERICA					4238		
17-02411	1	GARDEN STATE HWY PROD INC - Pu	256.45	7-01-20-670-259	Budget		84	1	
				FINANCIAL MGMT/PARKING REG-MINOR APPRTUS					
8602	09/20/17	BOAPCARD BANK OF AMERICA					4238		
17-02412	1	GLEESONS AUDIO VIDEO - Purchas	63.96	7-01-20-101-259	Budget		85	1	
				C/S-MUSIC PIER OPERATIONS MINOR APPRATUS					
8603	09/20/17	BOAPCARD BANK OF AMERICA					4238		
17-02413	1	GOPHER SPORT - Purchase	586.96	T-12-56-173-033	Budget		86	1	
				RECREATION TRUST PROGRAMS					
8604	09/20/17	BOAPCARD BANK OF AMERICA					4238		
17-02414	1	WW GRAINGER - Purchase	313.15	7-01-20-098-259	Budget		87	1	
				C/S-AQUATIC & FITNESS MINOR APPARATUS					
8605	09/20/17	BOAPCARD BANK OF AMERICA					4238		
17-02415	1	GRANTURK EDMNT CO INC - Purch	3,171.48	C-04-55-301-505	Budget		88	1	
				STREET SWEEPER					
8606	09/20/17	BOAPCARD BANK OF AMERICA					4238		
17-02416	1	F.W. WEBB - 106 - Toilet (12th	546.91	7-01-26-830-259	Budget		89	1	
				FACILITY MAINTENANCE - MINOR APPARATUS					

Check #	Check Date	Vendor	Amount Paid	Charge Account	Account Type	Reconciled/Void Contract	Ref Num
PO #	Item	Description					Ref Seq Acct
8607	09/20/17	BOAPCARD BANK OF AMERICA					4238
17-02417	1	HD SUPPLY FACILITIES MAI - Pur	179.48	7-01-26-830-259	Budget		90 1
				FACILITY MAINTENANCE - MINOR APPARATUS			
17-02417	2	HD SUPPLY FACILITIES MAI - Pur	179.48	7-01-26-830-259	Budget		91 1
				FACILITY MAINTENANCE - MINOR APPARATUS			
17-02417	3	HD SUPPLY FACILITIES MAI - Pur	565.20	7-01-26-830-259	Budget		92 1
				FACILITY MAINTENANCE - MINOR APPARATUS			
17-02417	4	HD SUPPLY FACILITIES MAI - Pur	904.80	7-01-26-830-259	Budget		93 1
				FACILITY MAINTENANCE - MINOR APPARATUS			
			<u>1,828.96</u>				
8608	09/20/17	BOAPCARD BANK OF AMERICA					4238
17-02418	1	THE HOME DEPOT #0930 - Purchas	594.52	7-01-20-650-259	Budget		94 1
				FINANCIAL MGMT/REV COLLECTION-MINOR APP			
17-02418	2	THE HOME DEPOT #0930 - Purchas	118.86	7-01-25-770-259	Budget		95 1
				PS/FIRE-MINOR APPARATUS			
17-02418	3	THE HOME DEPOT #0930 - Hand To	378.76	7-01-26-830-268	Budget		96 1
				FACILITY MAINTENANCE - GROUNDS KEEPING			
17-02418	4	THE HOME DEPOT #0930 - Purchas	563.10	7-01-26-840-259	Budget		97 1
				FIELD OPERATIONS - MINOR APPARATUS			
			<u>1,655.24</u>				
8609	09/20/17	BOAPCARD BANK OF AMERICA					4238
17-02419	1	SQ HUBER LOCKSMITH - Purchase	24.00	7-01-20-090-259	Budget		98 1
				C/S-PUBLIC RELATIONS & INFO MP OPERATNS			
8610	09/20/17	BOAPCARD BANK OF AMERICA					4238
17-02420	1	JESCO INC (MOUNT HOLLY) - Purc	627.82	7-01-26-880-259	Budget		99 1
				FLEET MAINTENANCE - MINOR APPARATUS			
17-02420	2	JESCO INC (MOUNT HOLLY) - Purc	1,701.61	7-01-26-880-259	Budget		100 1
				FLEET MAINTENANCE - MINOR APPARATUS			
			<u>2,329.43</u>				
8611	09/20/17	BOAPCARD BANK OF AMERICA					4238
17-02421	1	JOHNSTONE SUPPLY 266 - HVAC-Re	42.15	7-01-26-830-259	Budget		101 1
				FACILITY MAINTENANCE - MINOR APPARATUS			
17-02421	2	JOHNSTONE SUPPLY 266 - HVAC-Re	105.62	7-01-26-830-259	Budget		102 1
				FACILITY MAINTENANCE - MINOR APPARATUS			
17-02421	3	JOHNSTONE SUPPLY 266 - HVAC-Re	107.50	7-01-26-830-259	Budget		103 1
				FACILITY MAINTENANCE - MINOR APPARATUS			
17-02421	4	JOHNSTONE SUPPLY 266 - HVAC-Re	214.50	7-01-26-830-259	Budget		104 1
				FACILITY MAINTENANCE - MINOR APPARATUS			
17-02421	5	JOHNSTONE SUPPLY 266 - HVAC-Re	257.50	7-01-26-830-259	Budget		105 1
				FACILITY MAINTENANCE - MINOR APPARATUS			
17-02421	6	JOHNSTONE SUPPLY 266 - Mini Sp	263.20	7-01-26-830-259	Budget		106 1
				FACILITY MAINTENANCE - MINOR APPARATUS			
17-02421	7	JOHNSTONE SUPPLY 266 - HVAC-Re	297.50	7-01-26-830-259	Budget		107 1
				FACILITY MAINTENANCE - MINOR APPARATUS			
17-02421	8	JOHNSTONE SUPPLY 266 - HVAC-Re	322.00	7-01-26-830-259	Budget		108 1
				FACILITY MAINTENANCE - MINOR APPARATUS			
17-02421	9	JOHNSTONE SUPPLY 266 - HVAC-Re	406.67	7-01-26-830-259	Budget		109 1
				FACILITY MAINTENANCE - MINOR APPARATUS			

Check #	Check Date	Vendor	Amount Paid	Charge Account	Account Type	Reconciled/Void Contract	Ref Num	Ref Seq	Acct
8611		BANK OF AMERICA							
		Continued							
17-02421	10	JOHNSTONE SUPPLY 266 - HVAC-Re	412.02	7-01-26-830-259	Budget		110	1	
				FACILITY MAINTENANCE - MINOR APPARATUS					
17-02421	11	JOHNSTONE SUPPLY 266 - HVAC-Re	477.50	7-01-26-830-259	Budget		111	1	
				FACILITY MAINTENANCE - MINOR APPARATUS					
17-02421	12	JOHNSTONE SUPPLY 266 - HVAC-Re	1,333.50	C-04-55-301-308	Budget		113	1	
				GENERAL					
17-02421	13	JOHNSTONE SUPPLY 266 - HVAC-Re	5,686.07	C-04-55-301-302	Budget		112	1	
				PUBLIC WORKS HVAC SYSTEM REPLACEMENT					
			<u>9,925.73</u>						
8612	09/20/17	BOAPCARD BANK OF AMERICA							4238
17-02422	1	LAWSON PRODUCTS - Purchase	258.32	7-01-26-880-259	Budget		114	1	
				FLEET MAINTENANCE - MINOR APPARATUS					
8613	09/20/17	BOAPCARD BANK OF AMERICA							4238
17-02423	1	LIBERTY PARKS AND PLAYGRO - Re	2,097.00	C-04-55-301-410	Budget		115	1	
				GENERAL PROPERTY IMPROVEMENTS					
8614	09/20/17	BOAPCARD BANK OF AMERICA							4238
17-02424	1	LOGMEIN LOGMEININC.COM - Purch	184.99	7-01-25-740-265	Budget		116	1	
				PS/POLICE-EQUIPMENT OUTLAY					
8615	09/20/17	BOAPCARD BANK OF AMERICA							4238
17-02425	1	LOWES #01034 - Purchase	44.72	7-01-26-830-259	Budget		117	1	
				FACILITY MAINTENANCE - MINOR APPARATUS					
17-02425	2	LOWES #01034 - Purchase	65.86	7-01-26-830-259	Budget		118	1	
				FACILITY MAINTENANCE - MINOR APPARATUS					
17-02425	3	LOWES #01034 - Purchase	107.76	7-01-26-830-259	Budget		119	1	
				FACILITY MAINTENANCE - MINOR APPARATUS					
17-02425	4	LOWES #01034 - Purchase	124.94	7-01-26-830-259	Budget		120	1	
				FACILITY MAINTENANCE - MINOR APPARATUS					
17-02425	5	LOWES #01034 - Purchase	231.50	7-01-26-840-259	Budget		121	1	
				FIELD OPERATIONS - MINOR APPARATUS					
17-02425	6	LOWES #01034 - HVAC-Repair-AC	299.00	7-01-26-830-259	Budget		122	1	
				FACILITY MAINTENANCE - MINOR APPARATUS					
17-02425	7	LOWES #01034 - Purchase	387.27	7-01-26-840-259	Budget		123	1	
				FIELD OPERATIONS - MINOR APPARATUS					
17-02425	8	LOWES #01034 - Potting Soil (D	538.00	7-01-26-830-268	Budget		124	1	
				FACILITY MAINTENANCE - GROUNDS KEEPING					
17-02425	9	LOWES #01034 - Purchase	605.94	7-01-26-840-259	Budget		125	1	
				FIELD OPERATIONS - MINOR APPARATUS					
17-02425	10	LOWES #01034 - Purchase	703.62	7-01-26-840-259	Budget		126	1	
				FIELD OPERATIONS - MINOR APPARATUS					
			<u>3,108.61</u>						
8616	09/20/17	BOAPCARD BANK OF AMERICA							4238
17-02426	1	MARINE RESCUE PRODUCTS - Purch	1,515.00	7-01-25-730-265	Budget		127	1	
				PS/LIFEGUARDS-EQUIP OUTLAY					
8617	09/20/17	BOAPCARD BANK OF AMERICA							4238
17-02427	1	METRO SWIM - NJ RETAIL - Purch	264.00	7-01-25-730-265	Budget		128	1	
				PS/LIFEGUARDS-EQUIP OUTLAY					

Check #	Check Date	Vendor	Amount Paid	Charge Account	Account Type	Reconciled/Void Contract	Ref Num	Ref Seq	Acct
8618	09/20/17	BOAPCARD BANK OF AMERICA					4238		
17-02428	1	MSFT E040040VJC - Purchase	56.00	7-01-20-310-211	Budget		129	1	
				LAW/LEGAL-PROFESSIONAL SERVICES					
8619	09/20/17	BOAPCARD BANK OF AMERICA					4238		
17-02429	1	MONROE SYSTEMS FOR BUSINE - Pu	194.17	7-01-20-047-249	Budget		130	1	
				ADMIN/ENG&PROJECTS OFFICE SUPPLIES					
8620	09/20/17	BOAPCARD BANK OF AMERICA					4238		
17-02430	1	IBT NASHVILLE - Purchase	855.00	7-01-20-025-262	Budget		131	1	
				HUMAN RESOURCES - PHYSICALS & VACCIN					
17-02430	2	IBT NASHVILLE - Purchase	855.00	7-01-20-025-262	Budget		132	1	
				HUMAN RESOURCES - PHYSICALS & VACCIN					
			<u>1,710.00</u>						
8621	09/20/17	BOAPCARD BANK OF AMERICA					4238		
17-02431	1	NJMVC CARDIFF - Purchase	60.00	7-01-26-880-259	Budget		133	1	
				FLEET MAINTENANCE - MINOR APPARATUS					
8622	09/20/17	BOAPCARD BANK OF AMERICA					4238		
17-02432	1	NOR NORTHERN TOOL - Purchase	49.81	7-01-26-840-259	Budget		134	1	
				FIELD OPERATIONS - MINOR APPARATUS					
8623	09/20/17	BOAPCARD BANK OF AMERICA					4238		
17-02433	1	ORCHARDS HYDRAULIC SERVIC - Pu	1,067.70	C-04-55-301-508	Budget		135	1	
				VEHICLE REHAB					
17-02433	2	ORCHARDS HYDRAULIC SERVIC - Pu	2,802.55	C-04-55-274-402	Budget		136	1	
				STORM TRUCK					
17-02433	3	ORCHARDS HYDRAULIC SERVIC - Pu	3.12	G-02-40-173-011	Budget		137	1	
				CLEAN COMM.-OP 2001-2016					
17-02433	4	ORCHARDS HYDRAULIC SERVIC - Pu	1,229.44	G-02-40-173-011	Budget		138	1	
				CLEAN COMM.-OP 2001-2016					
17-02433	5	ORCHARDS HYDRAULIC SERVIC - Pu	2,513.85	G-02-40-173-011	Budget		139	1	
				CLEAN COMM.-OP 2001-2016					
			<u>7,616.66</u>						
8624	09/20/17	BOAPCARD BANK OF AMERICA					4238		
17-02434	1	PATCH PLAQUES - Purchase	367.90	7-01-25-740-265	Budget		140	1	
				PS/POLICE-EQUIPMENT OUTLAY					
8625	09/20/17	BOAPCARD BANK OF AMERICA					4238		
17-02435	1	PATTON ELECTRONICS COMPAN - Pu	38.31	7-01-25-745-265	Budget		141	1	
				PS/INFO TECHNOLOGY-EQUIPMENT OUTLAY					
8626	09/20/17	BOAPCARD BANK OF AMERICA					4238		
17-02436	1	PEMBERTON ELECTRICAL SUPP - Pu	58.70	7-01-26-830-259	Budget		142	1	
				FACILITY MAINTENANCE - MINOR APPARATUS					
17-02436	2	PEMBERTON ELECTRICAL SUPP - Pu	298.13	7-01-26-830-259	Budget		143	1	
				FACILITY MAINTENANCE - MINOR APPARATUS					
17-02436	3	PEMBERTON ELECTRICAL SUPP - Pu	1,824.00	7-01-26-830-259	Budget		144	1	
				FACILITY MAINTENANCE - MINOR APPARATUS					
			<u>2,180.83</u>						

Check #	Check Date	Vendor	Amount Paid	Charge Account	Account Type	Reconciled/Void Contract	Ref Num
PO #	Item	Description					Ref Seq Acct
8627	09/20/17	BOAPCARD BANK OF AMERICA					4238
17-02437	1	PENDERGAST SAFETY EQPT - Purch	950.00	7-01-25-730-265	Budget		145 1
				PS/LIFEGUARDS-EQUIP OUTLAY			
8628	09/20/17	BOAPCARD BANK OF AMERICA					4238
17-02438	1	QUEENSBORO INDUSTRIES - Purcha	269.55	7-01-25-745-259	Budget		146 1
				PS/INFO TECHNOLOGY-MINOR APPARATUS			
8629	09/20/17	BOAPCARD BANK OF AMERICA					4238
17-02439	1	V.E. RALPH & SON, INC - Purcha	99.50	7-01-25-720-253	Budget		147 1
				PS/RESCUE SERVICES-MED SUPPLIES			
17-02439	2	V.E. RALPH & SON, INC - Purcha	104.88	7-01-25-730-253	Budget		148 1
				PS/LIFEGUARDS-MEDICAL SUPPLIES			
17-02439	3	V.E. RALPH & SON, INC - Purcha	104.88	7-01-25-730-253	Budget		149 1
				PS/LIFEGUARDS-MEDICAL SUPPLIES			
17-02439	4	V.E. RALPH & SON, INC - Purcha	351.00	7-01-25-720-253	Budget		150 1
				PS/RESCUE SERVICES-MED SUPPLIES			
17-02439	5	V.E. RALPH & SON, INC - Purcha	390.00	7-01-25-730-253	Budget		151 1
				PS/LIFEGUARDS-MEDICAL SUPPLIES			
17-02439	6	V.E. RALPH & SON, INC - Purcha	478.00	7-01-25-720-253	Budget		152 1
				PS/RESCUE SERVICES-MED SUPPLIES			
17-02439	7	V.E. RALPH & SON, INC - Purcha	545.00	7-01-25-720-253	Budget		153 1
				PS/RESCUE SERVICES-MED SUPPLIES			
17-02439	8	V.E. RALPH & SON, INC - Purcha	2,128.60	7-01-25-720-253	Budget		154 1
				PS/RESCUE SERVICES-MED SUPPLIES			
17-02439	9	V.E. RALPH & SON, INC - Purcha	208.77	7-01-25-720-253	Budget		155 1
				PS/RESCUE SERVICES-MED SUPPLIES			
17-02439	10	V.E. RALPH & SON, INC - Purcha	135.20	7-01-25-720-253	Budget		156 1
				PS/RESCUE SERVICES-MED SUPPLIES			
			<u>4,545.83</u>				
8630	09/20/17	BOAPCARD BANK OF AMERICA					4238
17-02440	1	REGUYS.COM - Purchase	74.70	7-01-25-745-259	Budget		157 1
				PS/INFO TECHNOLOGY-MINOR APPARATUS			
8631	09/20/17	BOAPCARD BANK OF AMERICA					4238
17-02441	1	ROBERTS OXYGEN CO BR 00 - Purc	194.28	7-01-25-720-253	Budget		158 1
				PS/RESCUE SERVICES-MED SUPPLIES			
17-02441	2	ROBERTS OXYGEN CO BR 00 - Purc	220.43	7-01-25-720-253	Budget		159 1
				PS/RESCUE SERVICES-MED SUPPLIES			
17-02441	3	ROBERTS OXYGEN CO BR 00 - Purc	1,043.00	7-01-25-720-253	Budget		160 1
				PS/RESCUE SERVICES-MED SUPPLIES			
			<u>1,457.71</u>				
8632	09/20/17	BOAPCARD BANK OF AMERICA					4238
17-02442	1	RU CGS - Purchase	610.00	7-01-20-035-237	Budget		161 1
				PURCHASING - PROF EMPLOYEE RELATED			
8633	09/20/17	BOAPCARD BANK OF AMERICA					4238
17-02443	1	S&S WORLDWIDE - Purchase	47.19	T-12-56-173-033	Budget		162 1
				RECREATION TRUST PROGRAMS			

Check #	Check Date	Vendor	Amount Paid	Charge Account	Account Type	Reconciled/Void Contract	Ref Num
PO #	Item	Description					Seq Acct
8633		BANK OF AMERICA					
		Continued					
17-02443	2	S&S WORLDWIDE - Purchase	148.78	T-12-56-173-033	Budget		163 1
				RECREATION TRUST PROGRAMS			
			<u>195.97</u>				
8634	09/20/17	BOAPCARD BANK OF AMERICA					4238
17-02444	1	SAMSLUB.COM - Credit	178.77	T-12-56-173-033	Budget		164 1
				RECREATION TRUST PROGRAMS			
17-02444	2	SAMSLUB.COM - Purchase	1,081.18	T-12-56-173-033	Budget		165 1
				RECREATION TRUST PROGRAMS			
			<u>902.41</u>				
8635	09/20/17	BOAPCARD BANK OF AMERICA					4238
17-02445	1	TMS SANTA MONICA LIMOS - Purch	283.70	7-01-20-090-267	Budget		166 1
				C/S-PUBLIC RELATIONS & INFO	CW PROMOTNS		
8636	09/20/17	BOAPCARD BANK OF AMERICA					4238
17-02446	1	IN SCHOPPY'S SINCE 1921 - Pur	553.50	7-01-25-730-265	Budget		167 1
				PS/LIFEGUARDS-EQUIP OUTLAY			
8637	09/20/17	BOAPCARD BANK OF AMERICA					4238
17-02447	1	SEETON TURF MLNJ - Hand Tools-	472.43	7-01-26-830-268	Budget		168 1
				FACILITY MAINTENANCE - GROUNDS KEEPING			
8638	09/20/17	BOAPCARD BANK OF AMERICA					4238
17-02448	1	SHARP CLEANERS - Purchase	156.00	7-01-20-101-259	Budget		169 1
				C/S-MUSIC PIER OPERATIONS MINOR APPRATUS			
8639	09/20/17	BOAPCARD BANK OF AMERICA					4238
17-02449	1	SHEPPARD BUS SERVICE, INC - Pu	260.00	7-01-20-098-259	Budget		170 1
				C/S-AQUATIC & FITNESS MINOR APPARATUS			
17-02449	2	SHEPPARD BUS SERVICE, INC - Pu	260.00	7-01-20-098-259	Budget		171 1
				C/S-AQUATIC & FITNESS MINOR APPARATUS			
17-02449	3	SHEPPARD BUS SERVICE, INC - Pu	260.00	T-12-56-173-033	Budget		172 1
				RECREATION TRUST PROGRAMS			
17-02449	4	SHEPPARD BUS SERVICE, INC - Pu	270.00	T-12-56-173-033	Budget		173 1
				RECREATION TRUST PROGRAMS			
17-02449	5	SHEPPARD BUS SERVICE, INC - Pu	300.00	T-12-56-173-033	Budget		174 1
				RECREATION TRUST PROGRAMS			
			<u>1,350.00</u>				
8640	09/20/17	BOAPCARD BANK OF AMERICA					4238
17-02450	1	SHERWIN WILLIAMS 703760 - Purc	177.63	7-01-26-840-259	Budget		175 1
				FIELD OPERATIONS - MINOR APPARATUS			
8641	09/20/17	BOAPCARD BANK OF AMERICA					4238
17-02451	1	SHOEMAKER LUMBER CO INC - Purc	64.28	7-01-25-745-259	Budget		176 1
				PS/INFO TECHNOLOGY-MINOR APPARATUS			
17-02451	2	SHOEMAKER LUMBER CO INC - Purc	361.44	7-01-25-770-259	Budget		177 1
				PS/FIRE-MINOR APPARATUS			

Check #	Check Date	Vendor	Amount Paid	Charge Account	Account Type	Reconciled/Void Contract	Ref Num	Seq	Acct
8641		BANK OF AMERICA							
17-02451		3 SHOEMAKER LUMBER CO INC - Poly	40.64	7-01-26-830-268	Budget		178	1	
				FACILITY MAINTENANCE - GROUNDS KEEPING					
			<u>466.36</u>						
8642	09/20/17	BOAPCARD BANK OF AMERICA							4238
17-02452		1 SHOPRITE MARMORA S1 - Purchase	30.89	T-12-56-173-033	Budget		179	1	
				RECREATION TRUST PROGRAMS					
17-02452		2 SHOPRITE MARMORA S1 - Purchase	46.68	T-12-56-173-033	Budget		180	1	
				RECREATION TRUST PROGRAMS					
17-02452		3 SHOPRITE MARMORA S1 - Purchase	70.41	T-12-56-173-033	Budget		181	1	
				RECREATION TRUST PROGRAMS					
17-02452		4 SHOPRITE MARMORA S1 - Purchase	70.89	T-12-56-173-033	Budget		182	1	
				RECREATION TRUST PROGRAMS					
17-02452		5 SHOPRITE MARMORA S1 - Purchase	102.48	T-12-56-173-033	Budget		183	1	
				RECREATION TRUST PROGRAMS					
17-02452		6 SHOPRITE MARMORA S1 - Purchase	149.19	T-12-56-173-033	Budget		184	1	
				RECREATION TRUST PROGRAMS					
			<u>470.54</u>						
8643	09/20/17	BOAPCARD BANK OF AMERICA							4238
17-02453		1 SHORE TRUE VALUE - Purchase	38.95	7-01-25-740-259	Budget		185	1	
				PS/POLICE-MINOR APPARATUS					
8644	09/20/17	BOAPCARD BANK OF AMERICA							4238
17-02454		1 SIRCHIE FINGER PRINT LABO - Pu	198.90	7-01-25-740-233	Budget		186	1	
				PS/POLICE-EQUIP MAINT&REPAIR					
8645	09/20/17	BOAPCARD BANK OF AMERICA							4238
17-02455		1 BRIAN NIHILLS SPORTS S - Purch	966.50	7-01-26-840-243	Budget		187	1	
				FIELD OPERATIONS - UNIFORMS					
8646	09/20/17	BOAPCARD BANK OF AMERICA							4238
17-02456		1 STAPLS7180277926000001 - Purch	169.89	7-01-20-099-249	Budget		188	1	
				C/S-RECREATIONAL PROGRAMS OFF SUPPLIES					
17-02456		2 STAPLES DIRECT - Purchase	79.99	7-01-25-745-249	Budget		189	1	
				PS/INFO TECHNOLOGY-OFFICE SUPPLIES					
17-02456		3 STAPLES DIRECT - Purchase	393.26	7-01-26-810-249	Budget		190	1	
				ADMINISTRATION - OFFICE SUPPLIES					
			<u>643.14</u>						
8647	09/20/17	BOAPCARD BANK OF AMERICA							4238
17-02457		1 STAPLES 00115725 - Purch	8.39	7-01-20-610-249	Budget		192	1	
				FINANCIAL MGMT/ACCOUNTING-OFF SUPPLIES					
17-02457		2 STAPLES 00115725 - Purch	139.98	7-01-25-745-249	Budget		191	1	
				PS/INFO TECHNOLOGY-OFFICE SUPPLIES					
			<u>148.37</u>						
8648	09/20/17	BOAPCARD BANK OF AMERICA							4238
17-02458		1 STAR LITE PRODUCTIONS - Purcha	700.00	C-04-55-299-301	Budget		193	1	
				COMMUNICATION UPGRADES					

Check #	Check Date	Vendor	Amount Paid	Charge Account	Account Type	Reconciled/Void Contract	Ref Num
PO #	Item	Description					Seq Acct
8649	09/20/17	BOAPCARD BANK OF AMERICA					4238
17-02459	1	STINEMAN MANAGEMENT COR - Purc	92.16	T-12-56-173-033	Budget		194 1
				RECREATION TRUST PROGRAMS			
8650	09/20/17	BOAPCARD BANK OF AMERICA					4238
17-02460	1	STREAMHOSTER COM - Purchase	30.00	7-01-20-040-211	Budget		195 1
				ADMIN/EMERGENCY MGMT-PROF. SERVICES			
8651	09/20/17	BOAPCARD BANK OF AMERICA					4238
17-02461	1	STU STUMPS - Purchase	408.44	T-12-56-173-033	Budget		196 1
				RECREATION TRUST PROGRAMS			
8652	09/20/17	BOAPCARD BANK OF AMERICA					4238
17-02462	1	SQ TERENCE GUY - Purchase	485.50	7-01-25-770-275	Budget		197 1
				PS/FIRE-SAFETY EQUIPMENT			
8653	09/20/17	BOAPCARD BANK OF AMERICA					4238
17-02463	1	TLO TRANSUNION - Purchase	69.00	7-01-25-740-211	Budget		198 1
				PS/POLICE-PROF SERVICES			
8654	09/20/17	BOAPCARD BANK OF AMERICA					4238
17-02464	1	TUCKAHOE BIKE SHOP OC - Purcha	42.74	7-01-25-740-233	Budget		199 1
				PS/POLICE-EQUIP MAINT&REPAIR			
8655	09/20/17	BOAPCARD BANK OF AMERICA					4238
17-02465	1	VZWRLSS MY VZ VB P - Purchase	3,088.60	7-01-20-626-223	Budget		200 1
				TELEPHONE			
17-02465	2	VZWRLSS MY VZ VB P - Purchase	3,617.26	7-01-20-626-223	Budget		201 1
				TELEPHONE			
17-02465	3	VZWRLSS MY VZ VB P - Purchase	3,661.67	7-01-20-626-223	Budget		202 1
				TELEPHONE			
17-02465	4	VZWRLSS MY VZ VB P - Purchase	3,737.06	7-01-20-626-223	Budget		203 1
				TELEPHONE			
			<u>14,104.59</u>				
8656	09/20/17	BOAPCARD BANK OF AMERICA					4238
17-02466	1	Wallace True Value Hardwa - Pu	21.96	7-01-20-098-259	Budget		204 1
				C/S-AQUATIC & FITNESS MINOR APPARATUS			
17-02466	2	Wallace True Value Hardwa - Pu	58.19	7-01-20-098-259	Budget		205 1
				C/S-AQUATIC & FITNESS MINOR APPARATUS			
17-02466	3	Wallace True Value Hardwa - Pu	31.46	T-12-56-173-033	Budget		206 1
				RECREATION TRUST PROGRAMS			
17-02466	4	Wallace True Value Hardwa - Pu	89.24	T-12-56-173-033	Budget		207 1
				RECREATION TRUST PROGRAMS			
			<u>200.85</u>				
8657	09/20/17	BOAPCARD BANK OF AMERICA					4238
17-02467	1	WB MASON - Credit	256.16	7-01-20-098-249	Budget		208 1
				C/S-AQUATIC & FITNESS OFFICE SUPPLIES			
17-02467	2	WB MASON - Credit	122.64	7-01-20-047-249	Budget		209 1
				ADMIN/ENG&PROJECTS OFFICE SUPPLIES			
17-02467	3	WB MASON - Purchase	1.24	7-01-20-035-249	Budget		210 1
				PURCHASING - OFFICE SUPPLIES			

Check #	Check Date	Vendor	Amount Paid	Charge Account	Account Type	Reconciled/Void Contract	Ref Num	Ref Seq	Acct
8657		BANK OF AMERICA							Continued
17-02467	4	WB MASON - Purchase	3.99	7-01-20-090-249	Budget		211	1	C/S-PUBLIC RELATIONS & INFO OFF SUPPLIES
17-02467	5	WB MASON - Purchase	4.75	7-01-20-098-249	Budget		212	1	C/S-AQUATIC & FITNESS OFFICE SUPPLIES
17-02467	6	WB MASON - Purchase	17.13	7-01-20-098-249	Budget		213	1	C/S-AQUATIC & FITNESS OFFICE SUPPLIES
17-02467	7	WB MASON - Purchase	34.22	7-01-20-510-249	Budget		214	1	STATUTORY/MUNICIPAL COURT - OFFICE SUPPL
17-02467	8	WB MASON - Purchase	50.52	7-01-20-020-249	Budget		215	1	ADMIN/MUNICIPAL CODE,LIC & PZ OFF SUPP
17-02467	9	WB MASON - Purchase	56.18	7-01-20-090-249	Budget		216	1	C/S-PUBLIC RELATIONS & INFO OFF SUPPLIES
17-02467	10	WB MASON - Purchase	63.54	7-01-20-410-249	Budget		217	1	STATUTORY/CITY CLERK-OFFICE SUPPLIES
17-02467	11	WB MASON - Purchase	71.18	7-01-20-090-249	Budget		218	1	C/S-PUBLIC RELATIONS & INFO OFF SUPPLIES
17-02467	12	WB MASON - Purchase	76.53	7-01-20-047-249	Budget		219	1	ADMIN/ENG&PROJECTS OFFICE SUPPLIES
17-02467	13	WB MASON - Purchase	122.64	7-01-20-047-249	Budget		220	1	ADMIN/ENG&PROJECTS OFFICE SUPPLIES
17-02467	14	WB MASON - Purchase	124.18	7-01-20-096-249	Budget		221	1	C/S-NEIGHBORHOOD & SOC.SVCS-OFF SUPPLIES
17-02467	15	WB MASON - Purchase	136.81	7-01-20-610-249	Budget		222	1	FINANCIAL MGMT/ACCOUNTING-OFF SUPPLIES
17-02467	16	WB MASON - Purchase	256.16	7-01-20-098-249	Budget		223	1	C/S-AQUATIC & FITNESS OFFICE SUPPLIES
17-02467	17	WB MASON - Purchase	341.36	7-01-20-021-249	Budget		224	1	ADMINISTRATION/CONST CODE - OFF SUPPLIES
17-02467	18	WB MASON - Purchase	452.66	7-01-20-098-249	Budget		225	1	C/S-AQUATIC & FITNESS OFFICE SUPPLIES
17-02467	19	WB MASON - Purchase	494.50	7-01-20-625-223	Budget		226	1	FINANCIAL MGMT/CITY WIDE COPYING
17-02467	20	WB MASON - Purchase	502.68	7-01-20-510-249	Budget		227	1	STATUTORY/MUNICIPAL COURT - OFFICE SUPPL
17-02467	21	WB MASON - Purchase	562.08	7-01-20-020-249	Budget		228	1	ADMIN/MUNICIPAL CODE,LIC & PZ OFF SUPP
17-02467	22	WB MASON - Purchase	788.46	7-01-20-047-249	Budget		229	1	ADMIN/ENG&PROJECTS OFFICE SUPPLIES
17-02467	23	WB MASON - Purchase	34.48	7-01-25-770-249	Budget		230	1	PS/FIRE-OFFICE SUPPLIES
17-02467	24	WB MASON - Purchase	35.10	7-01-25-770-249	Budget		231	1	PS/FIRE-OFFICE SUPPLIES
17-02467	25	WB MASON - Purchase	43.95	7-01-25-770-249	Budget		232	1	PS/FIRE-OFFICE SUPPLIES
17-02467	26	WB MASON - Purchase	69.90	7-01-25-770-249	Budget		233	1	PS/FIRE-OFFICE SUPPLIES
17-02467	27	WB MASON - Purchase	114.95	7-01-25-740-249	Budget		234	1	PS/POLICE-OFFICE SUPPLIES
17-02467	28	WB MASON - Purchase	209.94	7-01-25-745-249	Budget		235	1	PS/INFO TECHNOLOGY-OFFICE SUPPLIES
17-02467	29	WB MASON - Purchase	1,091.57	7-01-25-740-249	Budget		236	1	PS/POLICE-OFFICE SUPPLIES

Check #	Check Date	Vendor	Amount Paid	Charge Account	Account Type	Reconciled/Void Contract	Ref Num	Ref Seq	Acct
8657		BANK OF AMERICA							
		Continued							
17-02467	30	WB MASON - Purchase	269.07	7-01-26-810-249	Budget		237	1	
				ADMINISTRATION - OFFICE SUPPLIES					
17-02467	31	WB MASON - Purchase	475.38	C-04-55-301-303	Budget		238	1	
				29TH STREET FIRE HOUSE CONTENTS					
17-02467	32	WB MASON - Purchase	1,569.40	C-04-55-301-605	Budget		239	1	
				POLICE EQUIPMENT					
			<u>7,695.75</u>						
8658	09/20/17	BOAPCARD BANK OF AMERICA					4238		
17-02468	1	WEST MARINE #106 - Purchase	202.54	7-01-25-730-265	Budget		240	1	
				PS/LIFEGUARDS-EQUIP OUTLAY					
17-02468	2	WEST MARINE #106 - Purchase	619.56	7-01-25-770-275	Budget		241	1	
				PS/FIRE-SAFETY EQUIPMENT					
			<u>822.10</u>						
8659	09/20/17	BOAPCARD BANK OF AMERICA					4238		
17-02469	1	INTERSTATE BATTERIES - Purchas	92.40	7-01-26-830-259	Budget		242	1	
				FACILITY MAINTENANCE - MINOR APPARATUS					

Report Totals	<u>Paid</u>	<u>Void</u>	<u>Amount Paid</u>	<u>Amount Void</u>
Checks:	86	0	149,634.35	0.00
Direct Deposit:	<u>0</u>	<u>0</u>	<u>0.00</u>	<u>0.00</u>
Total:	86	0	149,634.35	0.00